



ELECTRONIC PRESSURE & TEMPERATURE SWITCHES

ONE SERIES

DURABLE, RELIABLE AND VERSATILE: UNITED ELECTRIC CONTROLS' ONE SERIES ELECTRONIC PRESSURE & TEMPERATURE SWITCHES – THE BEST CHOICE FOR BOTH NEW CONSTRUCTION AND PLANT INSTRUMENTATION UPGRADES.

PRODUCT BENEFITS AT A GLANCE:

- LARGE DIGITAL DISPLAY FOR STATUS & PROCESS INDICATION
- 100% PROGRAMMABLE SET POINT & DEADBAND FOR EASY ADJUSTABILITY
- SOLID-STATE DESIGN FOR HIGH-VIBRATION APPLICATIONS
- LOCAL & REMOTE DIAGNOSTICS REPORTING FOR MAXIMUM RELIABILITY
- EXPLOSION-PROOF, INTRINSICALLY SAFE AND NON-INCENDIVE MODELS AVAILABLE FOR HAZARDOUS LOCATIONS
- MULTIPLE APPROVALS INCLUDING:   



OVERVIEW

United Electric Controls (UE) is renowned for high-quality workmanship and product design, and the *One Series* carries this nearly 80-year tradition well beyond electromechanical switches. UE's *One Series* line of digital electronic pressure and temperature switches sets new standards for quality, reliability and versatility. Designed to meet the needs of harsh and hazardous applications, the *One Series'* advanced self-diagnostics and digital electronics provide the most reliable switches for a variety of diverse industries.

The *One Series from UE* allows you to choose from explosion-proof, intrinsically safe and non-incendive models that monitor gauge pressure, differential pressure or temperature. With up to two fully adjustable set points and deadbands, available 4-20 mA analog output, and absolutely no moving parts, these versatile instruments

can now be used in a wide variety of applications where switches weren't previously considered. Featuring a solid-state design, UE's *One Series* is your best choice for tough applications with high cycle rates, vibration and shock. For plant upgrades, there are a variety of power options ranging from 2-wire discrete and analog loop-powered models to externally powered models that can deliver up to 280 VAC at 10 amperes to the load.

With an integral digital display and 4-20 mA output, the *One Series from UE* can effectively do the job of three – replacing a switch, a gauge and a transmitter. Powerful yet easy to install, the *One Series from UE* features tamper-resistance, intuitive programming, and set-up that is fast and easy.

MAKE THE SMART CHOICE. THE ONE SERIES FROM UE IS:

- A reliable, cost-effective solution for upgrading plant instrumentation.
- Ideal for applications that demand a switch that never needs calibration, has programmable adjustability and 0.1% repeatability.
- Easily integrated into a safety instrumented system (SIS) that requires a smart self-diagnostic switch (FMEDA and SIL verification reports available upon request).

KEY FEATURES THAT SET UE'S ONE SERIES APART:



- Digital process display
- Programmable set point and deadband
- Self-diagnostic solid-state digital electronics
- Plug port detection
- Nuisance trip filtering
- Patented electronic IAW® self-diagnostics
- Min/Max process values memory
- 3-year warranty

INNOVATIVE TECHNOLOGY

The *One Series'* patented digital design requires extremely low-power, allowing it to operate from residual current derived from a typical programmable logic controller (PLC) or distributed computer system (DCS) discrete input. A micro-processor provides 0.5% accuracy and 0.1% repeatability while monitoring all switch functions, ensuring reliability. Electronic components are surface mounted and then

encapsulated, providing resistance to weather, shock and vibration. Software algorithms include a full-time watch dog, monitoring all vital system functions. Should a fault be detected, the *One Series from UE* will report on the display and use the discrete and analog signals for remote indication, providing the peace of mind that this switch will work when needed.

APPLICATION VERSATILITY

For alarm and shutdown switching applications, there is no better choice than the *One Series* family of electronic switches from United Electric Controls. Measuring gauge pressure, differential pressure or temperature, the extremely rugged and reliable *One Series* takes all of the guess-work out of monitoring process variables to prevent injury, loss and downtime. With its large digital display,

fully-adjustable deadband, and 100% solid-state design, the *One Series* is the obvious choice for plant upgrades and new construction projects. A built-in microprocessor includes digital repeatability and intelligent self-diagnostics, offering plant operators an extremely reliable and smart protection device.

Proven in use in literally thousands of diverse applications, UE has recently developed explosion-proof *One Series* models, extending this revolutionary switching technology to Zone 1 (Division 1) areas.

Here are just a few:

- Pumps and compressors – start/stop, optimizing, shutdown, staging
- Lubricating oil monitoring – sump temperature, bearing pressure, predictive maintenance
- Hydraulic oil pressure – high pressure monitoring, emergency shutdown, ram cycling
- Filter monitoring – automatic backwash, clog and change indication, proving flow
- Safety systems – safety integrity levels 1 & 2, alarm and shutdown, local switching, fast response time
- Plant upgrades – power and wastewater plant upgrades, drop-in replacement for mechanical switches



The most popular *One Series* application is for pump control.



The *One Series* and other switches monitoring lube oil on a gear box.



The explosion-proof *One Series* protecting a natural gas compressor.

SPECIFICATIONS

Power input/Switch output:

Model	Input Type (Range)	Switch Ratings (SPST)	Temperature Derating	Min. Load Requirement
2W2D00 2X2D00	2-Wire 24 VDC discrete input powered (12-30 VDC) @ 750 μ A (max)	12-30 VDC @ 40 mA		2.3 mA
2W4D00 2X4D00	2-Wire 48 VDC discrete input powered (30-50 VDC) @ 750 μ A (max)	30-50 VDC @ 40 mA		2.0 mA
2W3A00 2X3A00	2-Wire 120 V discrete input powered (90-130 VAC/VDC) @ 1 mA	90-130 VAC/VDC @ 0.1 A		3.75 mA
2WLP41 2XLP41	2-Wire 24 VDC analog input loop powered (10-36 VDC) @ 4-20 mA	0-140 VAC/VDC @ 0.6 A	8% per 10°C above 21°C	0 mA
2WLP43 2XLP43	2-Wire 24 VDC analog input loop powered (10-36 VDC) @ 4-20 mA	0-280 VAC/VDC @ 0.3 A		
4W3A01 4X3A01	4-Wire 120 VAC external power supply (90-130 VAC) @ 15mA	24-280 VAC @ 10 A	1.8 A per 10°C above 38°C	150 mA
8W2D42 8X2D42	8-Wire 24 VDC external power supply (10-30 VDC) @ 30 mA	SW1: 75-250 VAC @ 1.5 A SW2: 75-250 VAC @ 1.5 A	10% per 10°C above 21°C	50mA
8W2D44 8X2D44	8-wire 24 VDC external power supply (10-30 VDC) @ 30 mA	SW1: 75-250 VAC @ 1.5 A SW2: 0-140 VAC/VDC @ 0.6 A		
8W2D45 8X2D45	8-wire 24 VDC external power supply (10-30 VDC) @ 30 mA	SW1: 0-140 VAC/VDC @ 0.6 A SW2: 0-140 VAC/VDC @ 0.6 A	8% per 10°C above 21°C	0 mA

Accuracy:

0.5% of full range span, at room temperature

Repeatability:

0.1% of full range span

Ambient operating temperature range:

	Approved Operating Temperature Range			
	cULus (Division System)		cULus & ATEX (Zone System)	
2W2D	-40°F (-40°C)	185°F (85°C)	-40°F (-40°C)	140°F (60°C)
2W4D	NA	NA	NA	NA
2WLP	-40°F (-40°C)	176°F (80°C)	-40°F (-40°C)	140°F (60°C)
2W3A	-40°F (-40°C)	185°F (85°C)	-40°F (-40°C)	140°F (60°C)
4W3A	-40°F (-40°C)	158°F (70°C)	-40°F (-40°C)	140°F (60°C)
8W2D	-40°F (-40°C)	176°F (80°C)	-40°F (-40°C)	140°F (60°C)
2X2D	-40°F (-40°C)	185°F (85°C)	-40°F (-40°C)	185°F (85°C)
2X4D	-40°F (-40°C)	185°F (85°C)	-40°F (-40°C)	185°F (85°C)
2XLP	-40°F (-40°C)	176°F (80°C)	-40°F (-40°C)	176°F (80°C)
2X3A	-40°F (-40°C)	185°F (85°C)	-40°F (-40°C)	185°F (85°C)
4X3A	-40°F (-40°C)	158°F (70°C)	-40°F (-40°C)	158°F (70°C)
8X2D	-40°F (-40°C)	176°F (80°C)	-40°F (-40°C)	176°F (80°C)

Long-term stability:

\pm 0.25% of range/year maximum Display Operating Temperature Range 10°F (-12°C) 158°F (70°C)

Temperature drift:

0.03% of full scale per °C

Switch response time:

"Change-of-output" response \leq 60 mS (16.7 Hz) (for detection of full step change and change of output state, delay feature off)

Display response time:

400 mS (2.5 Hz)

Response time filtering (Delay):

Software-configurable between 250 mS and 2 seconds in 2X increments

Diagnostics (IAW®):

Open or shorted sensor; plugged port; power supply out of range; over and under-range conditions; microprocessor faults/failure; keypad short; switch fault

Output states:

Field selectable for 2-state or 3-state operation.

For 2-state operation: (Default Setting)

Output will remain in one state (open or close) during normal ("inside threshold") operation; change to the opposite state for "at and outside threshold" conditions.

Note: unit must be configured as normally closed (Open rise, Open fall) to distinguish between a diagnostic or other failure and a process upset.

Output states (cont.): For 3-state operation:
Output will remain in closed state during normal ("inside threshold") operation; change to open state to indicate a fault/failure; and rapidly change between closed and open (pulse) state during "at and outside threshold" conditions.
Pulse rates vary by model. Fast and slow rates are selectable. See installation manual for details.

Control modes: Field configurable for change of state above or below set point value. Software configurable for automatic or manual reset.

Analog output: 4-20 mA output, 700 ohms max. at 24 VDC, Field scalable, 2:1 turn down. Various faults are indicated at 0, 3.5, 22 and 24 mA. See installation manual for details. (2WLP, 2XLP, 8W2D, 8X2D models only)

Electrical characteristics:
(2-wire models only)

Model		Switch State (Max.)	
		V. Open	V. Closed
2W2D	2X2D	12-30 VDC @ 750 μ A	4.7 VDC @ 40 mA
2W4D	2X4D	30-50 VDC @ 1mA	5.0 VDC @ 40 mA
2W3A	2X3A	90-130 VAC/VDC @ 1 mA	13 VAC/VDC @ 100 mA

Enclosure: Type 4X/IP66 certified epoxy-coated aluminum construction

Faceplate: UV-resistant pressure sensitive keypad and display overlay

Cover: Epoxy-coated aluminum with tempered glass insert (explosion-proof models only)

Conduit: 1/2" NPT female stainless steel fitting; 3/4" NPT female aluminum casting (explosion-proof models only)

Display:

- Local 4 digit x 0.5" LCD
- I Am Working (IAW[®]) status arrows
- Process Variable
- Units of measure
- Switch status
- Latch status
- Set point value
- Deadband value
- Min/Max values
- Fault codes

Set point & deadband: User-configured, 100% adjustable over entire sensor operating range

Memory: Programming and data protected by non-volatile EEPROM

Effective transmission distance 2,000 feet at rated voltage for 2W2D and 2W3A

Sensors: **Gauge Pressure** – 316 stainless steel, welded diaphragm, 1/2" NPT (female) process connection, micro-machined piezo-resistive strain gauge silicon element, 0.25 ml silicone oil fill.
Media temperature: -40 to 257°F (-40 to 125°C)

Differential Pressure - 316 stainless steel, welded diaphragms, 1/4" NPT (male) process connections, piezo-resistive strain gauge silicon element, silicone oil fill.
Media temperature: -40 to 257°F (-40 to 125°C)

Temperature – 316 stainless steel 0.25" OD sheath containing a 100 ohm 4-wire platinum RTD element available with epoxy fill (local low temp) or powder fill (remote high temp).
Media temperature: -300 to 1000°F (-184 to 538°C)

EMI/RFI: Compliance to CE EMC requirements: EN 55011, EN 61326, EN 61000-6-2

Emission: EN 55011 class A; Radiated emissions
EN 61000-3-2 Harmonic Current Emissions

Immunity: EN 61000-3-3 Immunity to Voltage Fluctuations and Flicker
EN 61000-4-2 Immunity to Electrostatic Discharge
EN 61000-4-3 Immunity to Continuous Radiated Disturbances
EN 61000-4-4 Immunity to Electrical Fast Transients
EN 61000-4-5 Immunity to Surges
EN 61000-4-6 Immunity to Continuous Conducted Disturbances
EN 61000-4-8 Immunity to Power Frequency Magnetic Field
EN 61000-4-11 Immunity to Voltage Dips and Interruptions

Shock: Consult factory

IAW[®] is a registered trademark of United Electric Controls Co. Specifications subject to change without notice

HOW TO ORDER

Build a part number by selecting the model, sensor and options from the tables below.

Model	Description	Min. Load	Zone			Division	
			0	1	2	1	2
2W2D00	2-wire discrete input powered, 12-30 VDC, 40 mA switch (24 VDC 2-Wire)	2.3 mA	✓	✓	✓	✓	✓
2X2D00				✓	✓	✓	✓
2W4D00	2-wire discrete input powered, 30-50 VDC, 40 mA switch (48 VDC 2-Wire)	2.0 mA					
2X4D00				✓	✓	✓	✓
2W3A00	2-wire discrete input powered, 90-130 VAC or VDC, 100 mA switch (115 VAC 2-Wire)	3.75 mA			✓		✓
2X3A00				✓	✓	✓	✓
2WLP41	2-wire loop-powered or 24V external powered, 4-20 mA output, 0-140 VAC/VDC, 0.6 A SSR	0 mA			✓		✓
2XLP41				✓	✓	✓	✓
2WLP43	2-wire loop-powered or 24V external powered, 4-20 mA output, 0-280 VAC/VDC, 0.3 A SSR	0 mA			✓		✓
2XLP43				✓	✓	✓	✓
4W3A01	External powered by 90-130 VAC, 24-280 VAC, 10 A SSR	150 mA			✓		✓
4X3A01				✓	✓	✓	✓
8W2D42	External powered by 10-30 VDC, SW1 & SW2: 75-250 VAC, 1.5 A SSR, 4-20 mA output	SW1: 50 mA SW2: 50 mA			✓		✓
8X2D42				✓	✓	✓	✓
8W2D44	External powered by 10-30 VDC, SW1: 75-250 VAC, 1.5 A SSR, SW2: 0-140 VAC/VDC, 0.6 A SSR, 4-20 mA output	SW1: 50 mA SW2: 0 mA			✓		✓
8X2D44				✓	✓	✓	✓
8W2D45	External powered by 10-30 VDC, SW1 & SW2: 0-140 VAC/VDC, 0.6 A SSR, 4-20 mA output	SW1: 0 mA SW2: 0 mA			✓		✓
8X2D45				✓	✓	✓	✓

Sensor	Pressure Operating Range ¹ + display resolution				Maximum Over Range ²	
Gauge pressure, piezo-resistive strain gage, silicon oil fill, 316L stainless wetted materials, 1/2" NPT (female) process connection, displayed as shown.						
P10	0-5.00 psig	344,7 mbar	34.47 kPa	0.352 kg/cm ²	10 psig	690 mbar
P11	0-15.00 psig	1034 mbar	103.4 kPa	1.055 kg/cm ²	30 psig	2068 mbar
P12	0-30.00 psig	2068 mbar	206.8 kPa	2.109 kg/cm ²	60 psig	4137 mbar
P13	0-50.00 psig	3447 mbar	344.7 kPa	3.516 kg/cm ²	100 psig	6895 mbar
P14	0-100.0 psig	6895 mbar	689.5 kPa	7.031 kg/cm ²	200 psig	13,8 bar
P15	0-300.0 psig	20,68 bar	2068 kPa	21.09 kg/cm ²	600 psig	41,4 bar
P16	0-500.0 psig	34,47 bar	3447 kPa	35.16 kg/cm ²	1000 psig	68,9 bar
P17	0-1000 psig	68,95 bar	6895 kPa	70.31 kg/cm ²	2000 psig	137,9 bar
P18	0-3000 psig	206,8 bar	20.68 mPa	210.9 kg/cm ²	6000 psig	413,7 bar
P19	0-4500 psig	310,3 bar	31.03 mPa	316.4 kg/cm ²	9000 psig	620,5 bar
P20*	0-6000 psig	413,7 bar	41.40 mPa	421.9 kg/cm ²	12000 psig	827,4 bar

For bar, kPa and kg/cm², the option code must be specified (see pg. 7)

* (P20 range available on 2X, 4X and 8X models only)

Sensor	Pressure Operating Range ¹ + display resolution				Maximum Over Range ²		Maximum Working Pressure ³	
Differential pressure, piezo-resistive strain gage, silicone oil fill, 316L stainless wetted materials, 1/4" NPT (male) process connections, displayed as shown.								
K11	0-50.0 psid	3447 mbar	344.7 kPa	3.516 kg/cm ²	100 psid	6895 mbar	500 psig	34,47 bar
K12	0-100.0 psid	6895 mbar	689.5 kPa	7.031 kg/cm ²	200 psid	13,8 bar	1500 psig	103,4 bar
K13	0-200.0 psid	13,8 bar	1379 kPa	14.10 kg/cm ²	400 psid	27,6 bar	1500 psig	103,4 bar

1 - The pressure range that the sensor will perform within specified tolerances.

2 - The maximum pressure that can be applied without affecting sensor performance.

3 - The maximum pressure that can be applied to both ports simultaneously without affecting sensor performance. Pressure on the "H" sensor port must be ≥ pressure on the "L" sensor port.

HOW TO ORDER CONT.

Sensor	Temperature Range	Description
Temperature – 4-wire RTD, 100 Ω platinum, DIN 0.00385, 0.25" OD sensor sheath, 316 stainless steel construction		
TL1	-40 to 450°F/-40 to 232°C (Consider option W073) (See page 8 for more information)	Local (stem) mounted rigid to enclosure, 4" sheath length
TL2		Local (stem) mounted rigid to enclosure, 6" sheath length
TL3		Local (stem) mounted rigid to enclosure, 10" sheath length
TR1		Remote mounted, 6" sheath, 6' fixed-length Teflon® extension. (2.5" sheath and MI extension for 2X, 4X and 8X models)
TRC		Remote mounted, 6" sheath, 1' to 30' in 1' increments variable Teflon® extension length MUST BE SPECIFIED. Consider Option M006. (2.5" sheath and MI extension for 2X, 4X and 8X models)
TH1	-40 to 1000°F/-40 to 538°C (Consider options W074 and W080)	Remote mounted, 2.5" sheath, 6' MI fixed extension length
THC		Remote mounted, 2.5" sheath, 2W2D, 2X2D, 2W4D, 2WLP, 2XLP, 8W2D and 8X2D models only, 1' to 30' MI extension length MUST BE SPECIFIED. USE OPTION W074 ONLY.
TC1	-300 to 200°F/-184 to 93°C (Consider options W074 and W080)	Remote mounted, 2.5" sheath, 6' MI fixed extension length
TCC		Remote mounted, 2.5" sheath, 2W2D, 2X2D, 2W4D, 2WLP, 2XLP, 8W2D & 8X2D models only, 1' to 30' MI extension length MUST BE SPECIFIED. USE OPTION W074 ONLY.
TTC	-40 to 900°F/-40 to 482°C (Example: TTC-NUN6-L 10.5)	Local (stem) spring-loaded mount, NUN connection lengths: 4" – 10" in 1" increments, variable sheath (L) length up to 60", BOTH MUST BE SPECIFIED, available on 2X, 4X and 8X models only. Refer to drawing on page 9. Thermowell required, see page 8.
TU1	-300 to 200°F/-184 to 93°C	User-supplied sensor for explosion-proof models only must be 4-wire RTD, 100 Ω platinum, DIN 0.00385 (response curve for RTD). Choose range expected for the application. See below to order replacement sensors.
TU2	-40 to 450°F/-40 to 232°C	
TU3	-40 to 1000°F/ -40 to 538°C	
Thermowells and fittings are shown on page 8. To order spares and replacement temperature sensor assemblies, available only on explosion-proof models , provide the "TA#:" number from the product nameplate. Example: TA#: 62128723		

OPTION CODES

- HL1** Hazardous location certificate
- M006** Add armor to temperature sensor Teflon® extension (2W, 4W, 8W, TR1 and TRC models only)
- M036** Transformer isolated IS barrier for model 2W2D only (use 62169-29 if ordered separately)
- M201** Factory set parameters (set point, deadband, switch mode **required when ordering**)
- M202** Factory set parameters for 2 switches (use with 8W2D and 8X2D only: **2 of each parameter required**)
- M270** Display units, degrees C for temperature models
- M275** Display units, inches of water column (P10, P11 and K11 sensor ranges only)
- M276** Display units, bar or mbar
- M277** Display units, kPa or MPa
- M278** Display units, kg/cm²
- M406** Compliance per Russian Gosgortekhnadzor (pending for explosion-proof models, call for availability)
- M419** ATEX approval (2W2D, 2W3A, 2WLP and 8W2D models only. N/A on 2W4D/4W3A. Standard on explosion-proof models.)
- M444** Paper tag
- M446** Stainless steel tag
- M449** Mounting adapter plate kit 62169-40 (use to match JIC form bolt pattern on 2W, 4W and 8W models only)
- M550** Oxygen cleaning service
- M905** 1/2" NPT female conduit added to right wall of enclosure for 2W2D, 2W3A, 2W4D and 4W3A models only
- M906** 1/2" NPT female conduit moved to bottom wall of enclosure for 2W2D, 2W3A, 2W4D and 4W3A models only, approvals N/A, see option M449, not available with differential pressure (K) sensors
- M907** 1/2" NPT female conduit moved from right to top wall of enclosure for 2WLP and 8W2D models only, approvals N/A, see option M449
- W073** 1/2" NPT male compression fitting for use with all TL and TR sensors, see page 8 for additional information
- W074** 1/2" NPT male union connector for use with all TR, TH and TC sensors for 2W2D, 2X2D, 2W4D, 2WLP, 2XLP, 8W2D and 8X2D models
- W080** 1/2" NPT male union connector for use with TH1 and TC1 sensors for 2W3A, 2X3A, 4W3A and 4X3A models
- W930** 1/2" NPT male to G1/2 male adapter for use with gauge pressure sensors P10-P20. Use part number 6361-762 if ordered separately.
- W932** 1/4" NPT female to G1/2 male adapter for use with differential pressure sensors K11-K13. Use part number 6361-763 if ordered separately (2 required)

TEMPERATURE SENSORS AND FITTINGS COMPATIBILITY CHART

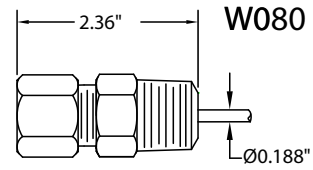
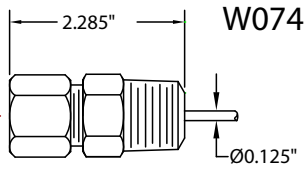
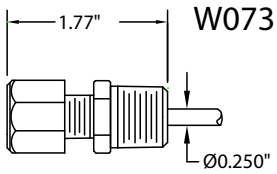

Model (Table 1)	W073 1/2" NPT compression fitting with ferrule to fit 0.25" sensor sheath	W074 1/2" NPT union connection to fit 0.125" sensor extension cable	W080 1/2" NPT union connection to fit 0.188" sensor extension cable
2W2D, 2W4D, 2WLP, 8W2D	TLx, TRx	TRx, THx, TCx	
2W2D, 2WLP, 8W2D (w/ ATEX option - M419)	TLx	TRx, THx, TCx	
2W3A, 4W3A	TLx, TRx		TH1, TC1
2W3A (w/ ATEX option - M419)	TLx		TR1, TH1, TC1
2X2D, 2X4D, 2XLP, 8X2D	TLx	TRx, THx, TCx	
2X3A, 4X3A	TLx		TR1, TH1, TC1

*The sensor extension is mineral insulated (MI) when ATEX option M419 is specified.

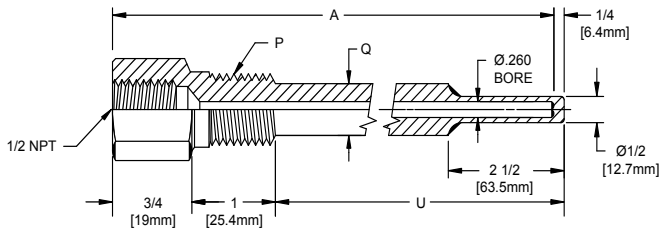

Fittings for Thermowells (Table 2)

Thermowell UE Part #	Length (A) Inches	P (NPT)	Q	U	Local Temperature Sensors w/ 0.25" Sensor Sheath ¹			Remote Temperature Sensors w/ Teflon® Cable	Remote Temperature Sensors w/ 0.125" Diameter MI Cable ¹	Remote Temperature Sensors w/ 0.188" Diameter MI Cable ¹
					TL1 (4")	TL2 (6")	TL3 (10")			
1S260 L4-316	4	1/2	5/8	2.5	-	W073	W073	W073	W074	W080
1S260 L5.5-316	5.5	1/2	5/8	4	-	-	W073	W073	W074	W080
1S260 L6-316	6	1/2	5/8	4.5	-	-	W073	W073	W074	W080
1S260 L6.5-316	6.5	1/2	5/8	5	-	-	W073	W073	W074	W080
1S260 L9-316	9	1/2	5/8	7.5	-	-	-	W074	W074	W080
1S260 L9.5-316	9.5	1/2	5/8	8	-	-	-	W074	W074	W080
1S260 L12-316	12	1/2	5/8	10.5	-	-	-	W074	W074	W080
1S260 L15-316	15	1/2	5/8	13.5	-	-	-	W074	W074	W080
1S260 L18-316	18	1/2	5/8	16.5	-	-	-	W074	W074	W080
1S260 L24-316	24	1/2	5/8	22.5	-	-	-	W074	W074	W080
2S260 L4-316	4	3/4	3/4	2.5	-	W073	W073	W073	W074	W080
2S260 L6-316	6	3/4	3/4	4.5	-	-	W073	W073	W074	W080
2S260 L9-316	9	3/4	3/4	7.5	-	-	-	W074	W074	W080
2S260 L12-316	12	3/4	3/4	10.5	-	-	-	W074	W074	W080
2S260 L15-316	15	3/4	3/4	13.5	-	-	-	W074	W074	W080
2S260 L18-316	18	3/4	3/4	16.5	-	-	-	W074	W074	W080
2S260 L24-316	24	3/4	3/4	22.5	-	-	-	W074	W074	W080

Note:

- Reference (Table 1) to determine sensor sheath diameter or the diameter of the MI cable by model

DIMENSIONAL DRAWINGS

ENCLOSURE AND SENSOR DETAILS

2X, 4X and 8X Models
(Shown with gauge pressure sensor)

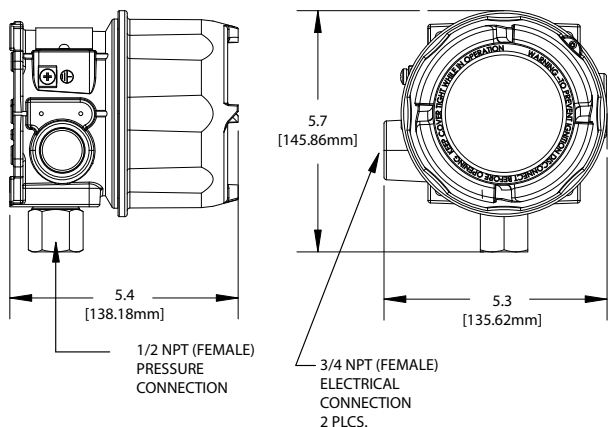

2W, 4W and 8W Models
(Single conduit shown with gauge pressure sensor)

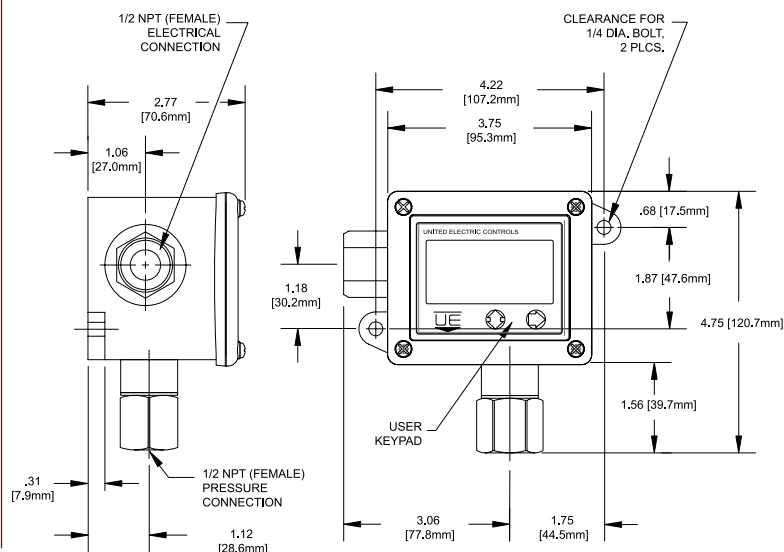

TEMPERATURE SENSORS

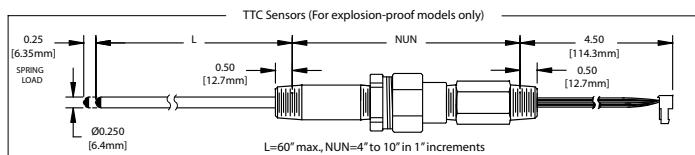
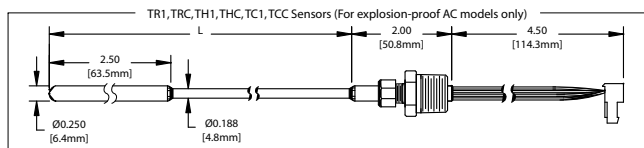
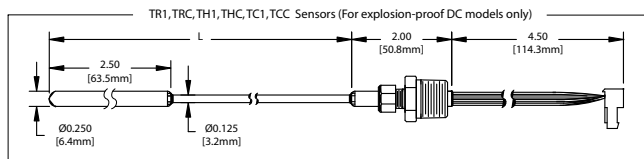
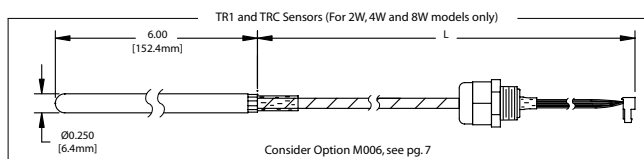
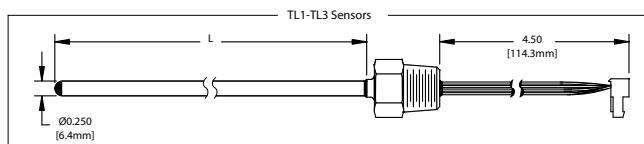

GAUGE PRESSURE SENSORS

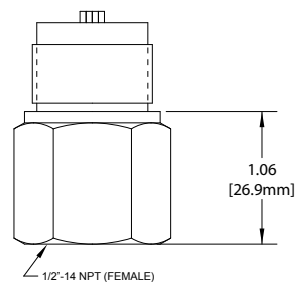

DIFFERENTIAL PRESSURE SENSORS

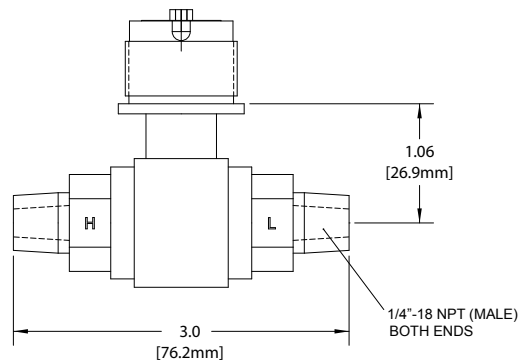

APPROVALS & RATINGS

Model	N. America UL Listed, cUL Certified UL50, 508, 913, 1604 & 60079-15; CSA No. E79-0, E79-11, E60079-15, C22.2 No. 14, 157 & 213 File#E226592	Europe (select option M419) (ATEX Directive 94/9/EC) EN 60079-0, 60079-15, 50281-1-1, 50020	Australia IECEx Scheme	Russia (select option M406) Gosgortekhnadzor
2W2D Intrinsically safe when used with a safety barrier (option M036)	Class I, Div 1, Groups A, B, C & D Class II, Div 1, Groups E, F & G Class III Class I, Zone 0, AEx ia IIC T5 Class I, Zone 0, Ex ia IIC T5 Per UE drawing # A-62174-19	II 1 G EEx ia IIC T5 II 1 D T+90°C, IP66 T _{AMB} = -40°C to +60°C Per UE drawing # A-62174-20 Cert# DEMKO 03 ATEX 0322281X	N/A	OExIIICT5 T _{AMB} = -40°C to +85°C Cert# RRS 00-22739
2W2D Non-incendive	Class I, Div 2 Groups A, B, C & D Class II, Div 2 Groups F & G Class III Class I, Zone 2, AEx nC IIC T5 Class I, Zone 2 Ex nC IIC T5	II 3 G EEx nL IIC T5 II 3 D T+90°C, IP66 T _{AMB} = -40°C to +60°C Cert# DEMKO 03 ATEX 0322281X	N/A	ExnLIICT5 T _{AMB} = -40°C to +85°C Cert# RRS 00-22739
2W3A Non-incendive	Class I, Div 2 Groups A, B, C & D Class II, Div 2 Groups F & G Class III Class I, Zone 2, AEx nC IIC T5 Class I, Zone 2 Ex nC IIC T5	II 3 G Ex nL IIC T5 II 3 D T+90°C, IP66 T _{AMB} = -40°C to +60°C Cert# DEMKO 08 ATEX 0726838X	N/A	ExnLIICT5 T _{AMB} = -40°C to +85°C Cert# RRS 00-22739
2W4D	N/A	N/A	N/A	N/A
2WLP Non-incendive	Class I, Div 2 Groups A, B, C & D Class II, Div 2 Groups F & G Class III Class I, Zone 2, AEx nC IIC T4 Class I, Zone 2 Ex nC IIC T4	II 3 G Ex nL IIC T4 II 3 D T+110°C, IP66 T _{AMB} = -40°C to +60°C Cert# DEMKO 08 ATEX 0726838X	N/A	ExnLIICT4 T _{AMB} = -40°C to +80°C Cert# RRS 00-22739
4W3A Non-incendive	Class I, Div 2 Groups A, B, C & D Class II, Div 2 Groups F & G Class III Class I, Zone 2, AEx nC IIC T4 Class I, Zone 2 Ex nC IIC T4	N/A	N/A	N/A
8W2D Non-incendive	Class I, Div 2 Groups A, B, C & D Class II, Div 2 Groups F & G Class III Class I, Zone 2, AEx nC IIC T4 Class I, Zone 2 Ex nC IIC T4	II 3 G Ex nL IIC T4 II 3 D T+110°C, IP66 T _{AMB} = -40°C TO +60°C Cert# DEMKO 08 ATEX 0726838X	N/A	ExnLIICT4 T _{AMB} = -40°C to +80°C Cert# RRS 00-22739
Model	N. America UL Listed, cUL Certified UL 50, 50E, 1203, UL/CSA 61010-1, 60079-0, 60079-1, CSA C22.2 No. 25,30 File#E226592	Europe (ATEX Directive 94/9/EC) EN 60079-0, 60079-1, 61241-0, 61241-1	Australia IECEx Scheme IEC 60079-0, 60079-1	Russia (select option M406) Gosgortekhnadzor
2X2D, 2X3A, 2X4D 2XLP, 4X3A, 8X2D Explosion-Proof/ Flameproof	Class I, Div 1, Groups A, B, C & D Class II, Div 1, Groups E, F & G Class III Class I, Zone 1, AEx nC IIC T3/T5** Class I, Zone 1 Ex nC IIC T5	II 2 G Ex d IIC T3/T5** II 2 D Ex tD A21 IP66 T+90°C Cert# DEMKO 09 ATEX 0813748X	Ex d IIC T3/T5** Cert# IECEx UL 08.0017X	N/A*

* Approval pending

**T3 for pressure sensor ranges P10-P16 only. T5 for all other models.

Specifications subject to change without notice.

ADDITIONAL PRODUCTS FROM UE

Spectra 12 Series – Electro-Mechanical Pressure and Temperature Switch

- Dual Seal Approved
- Compact, cylindrical 316 stainless steel enclosure
- Hermetically-sealed switch
- Explosion-proof
- Snap-acting belleville spring mechanism to enhance vibration resistance and set point stability
- Pressure ranges 1 to 12,500 psi;
DP working pressure ranges 0 to 2500 psid;
temperature ranges -130 to 650°F



120 Series – Electro-Mechanical Pressure and Temperature Switch

- Explosion-proof line of pressure, differential pressure, and temperature models with wide selection of ranges, sensors and pressure connections
- UL, cUL, ATEX certified for hazardous locations
- Single or dual switch outputs
- Internal or external set point adjustment



TX200 Series – Pressure Transmitters

- Welded, hermetically-sealed, 316 stainless steel construction
- Ranges 0 to 15 psi up to 0 to 25,000 psi
- Choice of field adjustable or fixed range models
- 4-20 mA or 1-5 VDC output



117 Series – Electro-Mechanical Pressure and Temperature Switch

- Single switch for corrosive and hazardous division 2 locations
- Compact pressure, differential pressure and temperature models
- Hermetically-sealed SPDT and DPDT output
- Epoxy-coated, weather-tight design houses stainless steel internal construction
- Convenient terminal block wiring

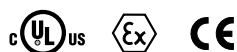

Temperature Sensors

Rugged RTDs and thermocouples for process and energy applications, available with Nema 4X and explosion-proof heads to match heat-trace, turbine, combustion, and stack-emission applications



RECOMMENDED PRACTICES AND WARNINGS

United Electric Controls Company recommends careful consideration of the following factors when specifying and installing UE pressure and temperature units. Before installing a unit, the Installation and Maintenance instructions provided with unit must be read and understood.

- To avoid damaging unit, proof pressure and maximum temperature limits stated in literature and on nameplates must never be exceeded, even by surges in the system. Operation of the unit up to maximum pressure or temperature is acceptable on a limited basis (e.g., start-up, testing) but continuous operation must be restricted to the designated adjustable range. Excessive cycling at maximum pressure or temperature limits could reduce sensor life.
- A back-up unit is necessary for applications where damage to a primary unit could endanger life, limb or property. A high or low limit switch is necessary for applications where a dangerous runaway condition could result.
- The adjustable range must be selected so that incorrect, inadvertent or malicious setting at any range point cannot result in an unsafe system condition.
- Install unit where shock, vibration and ambient temperature fluctuations will not damage unit or affect operation. When applicable, orient unit so that moisture does not enter the enclosure via the electrical connection. When appropriate, this entry point should be sealed to prevent moisture entry.
- Unit must not be altered or modified after shipment. Consult UE if modification is necessary.
- Monitor operation to observe warning signs of possible damage to unit, such as drift in set point or faulty display. Check unit immediately.
- Preventative maintenance and periodic testing is necessary for critical applications where damage could endanger property or personnel.
- Electrical ratings stated in literature and on nameplate must not be exceeded. Overload on a switch can cause damage, even on the first cycle. Wire unit according to local and national electrical codes, using wire size recommended in installation sheet.
- Do not mount unit in ambient temp. exceeding published limits.

LIMITED WARRANTY

Seller warrants that the product hereby purchased is, upon delivery, free from defects in material and workmanship and that any such product which is found to be defective in such workmanship or material will be repaired or replaced by Seller (Ex-works, Factory, Watertown, Massachusetts. INCOTERMS); provided, however, that this warranty applies only to equipment found to be so defective within a period of 36 months from the date of manufacture by the Seller. Seller shall not be obligated under this warranty for alleged defects which examination discloses are due to tampering, misuse, neglect, improper storage, and in any case where products are disassembled by anyone other than authorized Seller's representatives. EXCEPT FOR THE LIMITED WARRANTY OF REPAIR AND REPLACEMENT STATED ABOVE, SELLER DISCLAIMS ALL WARRANTIES WHATSOEVER WITH RESPECT TO THE PRODUCT, INCLUDING ALL IMPLIED WARRANTIES OF MERCHANTABILITY OR FITNESS FOR ANY PARTICULAR PURPOSE.

LIMITATION OF SELLER'S LIABILITY

SELLER'S LIABILITY TO BUYER FOR ANY LOSS OR CLAIM, INCLUDING LIABILITY INCURRED IN CONNECTION WITH (I) BREACH OF ANY WARRANTY WHATSOEVER, EXPRESSED OR IMPLIED, (II) A BREACH OF CONTRACT, (III) A NEGLIGENT ACT OR ACTS (OR NEGLIGENT FAILURE TO ACT) COMMITTED BY SELLER, OR (IV) AN ACT FOR WHICH STRICT LIABILITY WILL BE INPUTTED TO SELLER, IS LIMITED TO THE "LIMITED WARRANTY" OF REPAIR AND/OR REPLACEMENT AS SO STATED IN OUR WARRANTY OF PRODUCT. IN NO EVENT SHALL THE SELLER BE LIABLE FOR ANY SPECIAL, INDIRECT, CONSEQUENTIAL OR OTHER DAMAGES OF A LIKE GENERAL NATURE, INCLUDING, WITHOUT LIMITATION, LOSS OF PROFITS OR PRODUCTION, OR LOSS OR EXPENSES OF ANY NATURE INCURRED BY THE BUYER OR ANY THIRD PARTY.

UE specifications subject to change without notice.

U.S. SALES OFFICES

United Electric Controls
31 Old Stage Road
Hampton Falls, NH 03844
Phone: 617-899-1132
email: northeastsales@ueonline.com

United Electric Controls
28 N. Wise Ave.
Freeport, IL 61032
Phone: 815-341-2588
email: midwestsales@ueonline.com

United Electric Controls
1022 Vineyard Drive
Conyers, GA 30013
Phone: 770-335-9802
email: southeastsales@ueonline.com

United Electric Controls
5829 Grazing Court
Mason, OH 45040
Phone: 513-535-5486
email: midatlanticsales@ueonline.com

United Electric Controls
102 Salazar Court
Clayton, CA 94517
Phone: 925-408-5997
email: westcoastsales@ueonline.com

United Electric Controls
27 Summit Terrace
Sparta, NJ 07871
Phone: 973-271-2550
email: easternsales@ueonline.com

United Electric Controls
4306 Whickham Drive
Fulshear, TX 77441
Phone: 832-457-6138
email: southwestsales@ueonline.com

United Electric Controls
5201 Arbor Court
Odessa, TX 79762
Phone: 432-770-4164
email: westtexasales@ueonline.com

CANADA

EASTERN
68 Mosley Crescent
Brampton, Ontario
Canada L6Y 5C8
Phone: 905-455-5131
FAX: 905-455-5131

WESTERN
148 Silver Ridge Close N.W.
Calgary, Alberta
Canada T3B 3T4
Phone: 403-247-3724
FAX: 403-247-3724



UNITED ELECTRIC
CONTROLS

180 Dexter Avenue, P.O. Box 9143
Watertown, MA 02471-9143 USA
Telephone: 617 926-1000 Fax: 617 926-2568
<http://www.ueonline.com>

INTERNATIONAL OFFICES

CHINA
United Electric Controls, *Shanghai Office*
Room 1011, 10th Flr,
Huai Hai Zhonghua Building
No. 885, Renmin Road, Luwan District
Shanghai 200010, P.R. China
Phone: +8621-6255 8059
email: chinasales@ueonline.com

United Electric Controls, *Beijing Office*
Room 1006, Jainhao International Bldg.
Block D, No. 116
Zizhuyuanlu, Haidian District
Beijing, China 100089
Phone & Fax: +86-10-5893-0551
email: beijingsales@ueonline.com

EASTERN EUROPE & SCANDINAVIA
United Electric Controls
05-806 Komorow
Kujawska 5, Poland
Phone: +48 22 499 4804
email: easterneuropesales@ueonline.com

GERMANY
United Electric Controls
An Der Zentlinde 21
D-64711 Erbach, Germany
Phone: 496-062-7400
email: europesales@ueonline.com

INDIA
United Electric Controls
House no. 7, Kamalkunj Society
Nizampura,
Baraoda (Gujarat), India
Phone: +91 (-265) -2788654
email: indiasales@ueonline.com

ASIA-PACIFIC
United Electric Controls, Far East
No. 1-2-2, 2nd Floor
Jalan 4/101C
Cheras Business Centre
56100 Kuala Lumpur, Malaysia
Phone: 603-9133-4122
email: asiapacific@ueonline.com

MEXICO
United Electric Controls
Zacatecas # 206, Suite 20
Col Guadalupe CP 89120
Tampico, Tamaulipas Mexico
Phone: +52 833-217-5201
email: latinamericasales@ueonline.com

RUSSIA
United Electric Controls, Moscow
Elninskaya str., 15-140
Moscow, 121552 Russia
Phone: +7 (495) 792-88-06
email: russiansales@ueonline.com