

Metal Sealed Mass Flow Controller

GENERAL FEATURES AND BENEFITS

- High leak integrity (less than 10^{-10} atm-cc/sec He)
- Enhanced process (5 Ra avg.) internal finish (optional)
- Electropolished wetted surfaces (optional)
- Vented-polished internal threads
- Normally Closed Valve (Normally Open Valve optional)
- Wide flow range (0.06 sccm through 30,000 sccm N₂)
- Insensitive to mounting attitude
- Mechanically and electrically compatible with other mass flow controllers
- Electrically activated valve override
- Low command flow cutoff
- TTL compatible "valve off" and purge function
- 0(4)-20 mA I/O, 24 Vdc, *i*-series design (optional)
- Available with all popular process connections
- Downport C-Seal (optional)

DESCRIPTION

The Brooks® Model 5850EM Metal Sealed Mass Flow Controller has all the features of the standard Model 5850E plus all metal seals for outstanding leak integrity and cleanliness. The Model 5850EM eliminates the need for continuous monitoring and readjustment of gas pressures to provide a stable mass flow. The heart of the system is the highly stable sensor which produces an electrical output signal linear with flow rate. This signal is used for indicating, recording and/or control purposes without the need for an auxiliary auto-zero circuit.

PRINCIPLE OF OPERATION

The operating principle of the Brooks Mass Flow Controller is thermodynamic. A precision power supply directs heat to the midpoint of the sensor tube carrying the flow. On the same tube equidistant upstream and downstream of the heat input, are resistance temperature measuring elements.

With no flow, the heat reaching each temperature element is equal. With increasing flow, the flowstream carries heat away from the upstream element, T1 and an increasing amount towards the downstream element T2. An increasing temperature difference develops between the two elements and this difference is proportional to the amount of gas flowing or the mass flow rate. A bridge circuit interprets the temperature difference and an amplifier provides the output to the control circuitry as well as a 0-5 Vdc output signal.



The control circuitry compares the command set-point to the flow signal and positions the precision solenoid control valve. When the command signal is below 1% of full scale, the control valve is positioned fully closed. The control valve can be latched fully open or closed by activating the valve override circuit.

SPECIFICATIONS

Performance Characteristics:

Flow Ranges*

Any range from 0 to 3 sccm to -30,000 sccm Nitrogen equivalent. Lower flows available, consult factory.

*Standard: 0°C and 101 kPa (760 Torr). Per SEMI Guideline E12-96.

Control Range

- 2 - 100% with elastomeric valve seat
- 3 - 100% with metal or Teflon® valve seat

Brooks® Model 5850EM

Accuracy

1% Full scale including linearity, at calibration conditions
1.5% Full scale including linearity, for flow ranges greater than 20 slpm

Repeatability

0.25% of rate

Settling Time

Less than 3 seconds to within 2% of full scale of final value for a 0-100% command step with normally closed valve.*

Optional: Enhanced response PCB's provide 600 msec typical.

*Per SEMI Guideline E17-91.

Mounting Attitude Sensitivity

Available in any position
0.5% maximum full scale deviation after rezeroing

Temperature Sensitivity

Zero: Less than $\pm 0.075\%$ full scale per °C
Span: Less than $\pm 1.0\%$ full scale shift over 10-50°C range

Pressure Sensitivity

0.008% per psi Nitrogen

RATINGS:

Operating Pressure

1,500 psi (10.342 MPa) max.
Note: 500 psi with stainless steel fastener.

(PED) Pressure Equipment Directive (97/23/EC)
as Sound Engineering Practice (SED)

Differential Pressure

Valve orifice sized for any pressure drop between 5 to 50 psi (Minimum pressure drop depends on gas and range).

Ambient Temperature Limits

Operating: 40°F to 150°F (5°C to 65°C)
Non-Operating: -13°F to 212°F (-25°C to 100°C)

Leak Integrity

Inboard to outboard 1×10^{-10} atm. cc/sec. Helium max.

Physical Characteristics:

Materials of Construction

316L VAR (Vacuum Arc Remelt), 316L, and high alloy ferritic stainless steel.
External seals: Nickel 200.
Internal seals: Nickel.

Valve Seat: 316L, Viton® fluoroelastomers, Buna-N, Kalrez® or Teflon®.

Dimensions

Refer to Figures 1 and 2

Process Connections

1/4" Tube VCR™
Downport C-Seal

Electrical Characteristics:

Electrical Connections

Card edge: 30 microinch gold over low stress nickel-plated copper or 15 Pin D-Connector (DA-15P)

Command Input

Voltage Option: 0-5 Vdc (Input resistance 40 k ohm min.)
Current Option: 4-20 mAdc (Input Resistance 75 ohm)

Output Signal

Voltage Option: 0 to 5 Vdc into 2,000 ohms minimum
Current Option: Jumper selective 4-20 mAdc or 0-20 mAdc

5 Volt Reference Output

5 Volts, ± 0.01 Vdc into 2,000 ohms minimum

Power Requirements

Voltage Option:
N.C. Valve (or N.O. Valve with flow less than 2.5 slpm):
3.25 watts max., +15 Vdc @ 35 mA -15 Vdc @ 180 mA
N.O. Valve with flow rate greater than 2.5 slpm: 10.5 watts max., +15 Vdc @ 350 mA, -15 Vdc @ 350 mA

Current Option:
+15 Vdc to +28 Vdc: 3.68 Watts min, +15 Vdc @ 245 mA
10.36 Watts max., +28 Vdc @ 370 mA

Power Supply Sensitivity

None within $\pm 5\%$ of specified voltage (See Power Requirements)

EMC Directive (89/336/EEC) per 61326.

TRADEMARKS

Brooks Brooks Instrument, LLC
Kalrez DuPont Dow Elastomers
Teflon E. I. DuPont de Nemours & Co.
VCR Cajon Co.
Viton DuPont Performance Elastomers

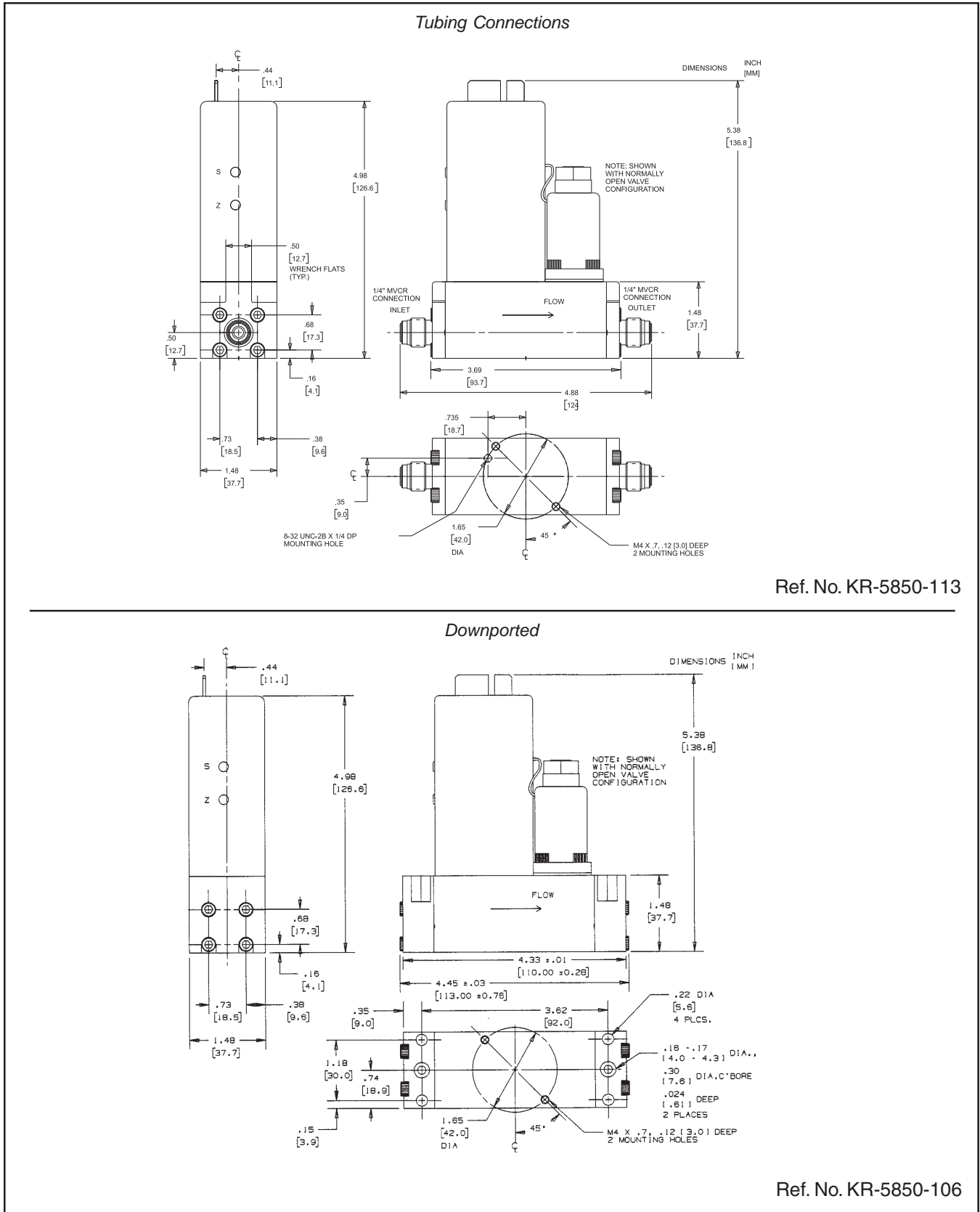

Figure 1 Model 5850EM Card Edge Dimensions

Brooks® Model 5850EM

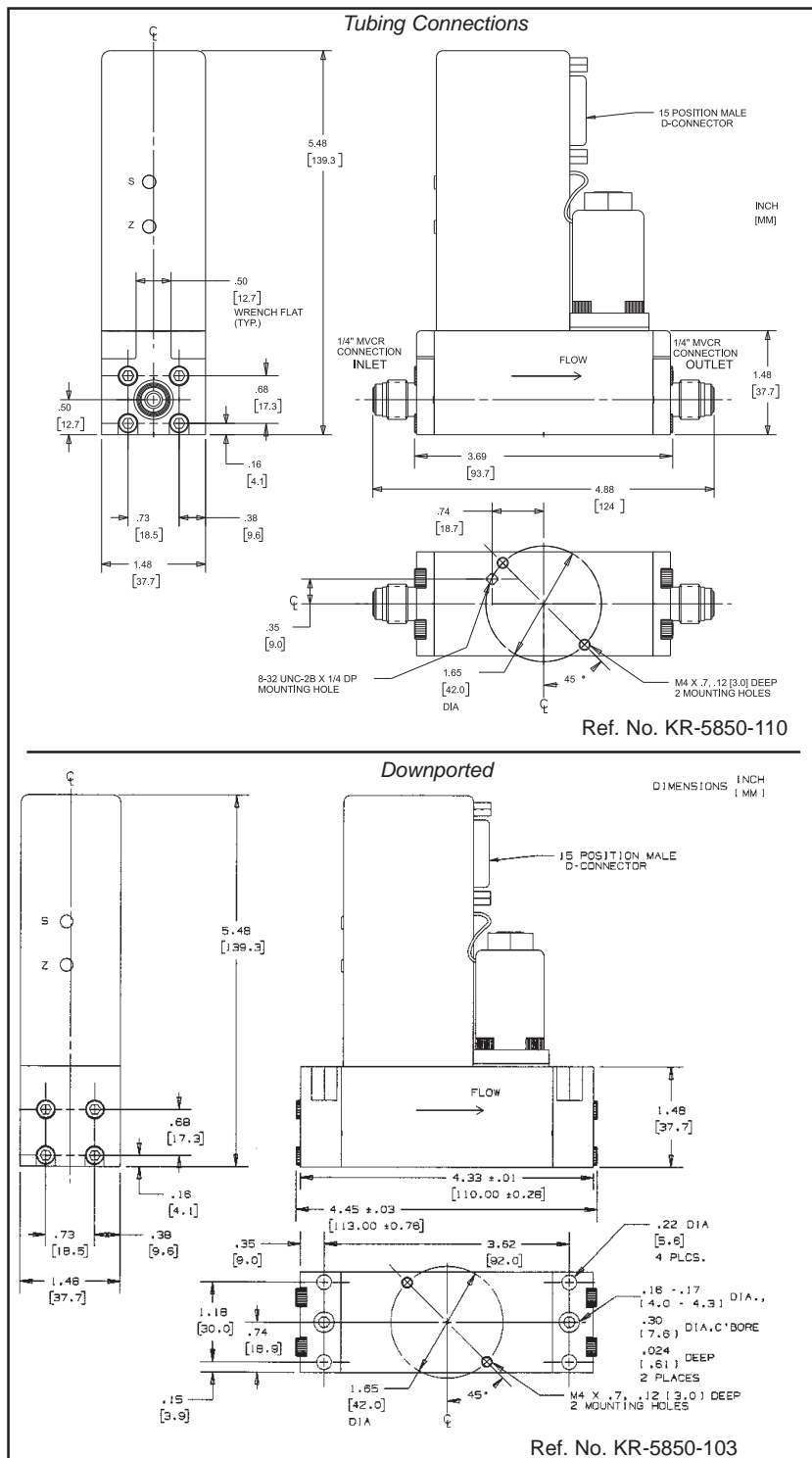

Figure 2 Model 5850EM D-Connector Dimensions

Brooks Instrument
 407 West Vine Street
 P.O. Box 903
 Hatfield, PA 19440-0903 USA
 T (215) 362-3700
 F (215) 362-3745
 E-Mail BrooksAm@BrooksInstrument.com
www.BrooksInstrument.com

Brooks Instrument
 Neonstraat 3
 6718 WX Ede, Netherlands
 T 31-318-549-300
 F 31-318-549-309
 E-Mail BrooksEu@BrooksInstrument.com

BROOKS SERVICE AND SUPPORT

Brooks is committed to assuring all of our customers receive the ideal flow solution for their application, along with outstanding service and support to back it up. We operate first class repair facilities located around the world to provide rapid response and support. Each location utilizes primary standard calibration equipment to ensure accuracy and reliability for repairs and recalibration. The primary standard calibration equipment to calibrate our flow products is certified by our local Weights and Measures Authorities and traceable to the relevant International Standards.

Visit www.BrooksInstrument.com to locate the service location nearest to you.

START-UP SERVICE AND IN-SITU CALIBRATION

Brooks Instrument can provide start-up service prior to operation when required. For some process applications, where ISO-9001 Quality Certification is important, it is mandatory to verify and/or (re)calibrate the products periodically. In many cases this service can be provided under in-situ conditions, and the results will be traceable to the relevant international quality standards.

CUSTOMER SEMINARS AND TRAINING

Brooks can provide customer seminars and dedicated training to engineers, end users and maintenance persons. Please contact your nearest sales representative for more details.

HELP DESK

In case you need technical assistance:

Americas ☎ 1-888-554-FLOW
 Europe ☎ +(31) 318 549 290
 Within Netherlands ☎ 0318 549 290
 Asia ☎ +011-81-3-5633-7100

Due to Brooks Instrument's commitment to continuous improvement of our products, all specifications are subject to change without notice.

Brooks Instrument
 1-4-4 Kitasuna Koto-Ku
 Tokyo, 136-0073 Japan
 T 011-81-3-5633-7100
 F 011-81-3-5633-7101
 E-Mail BrooksAs@BrooksInstrument.com

