

Data Sheet

DS-TMF-5860E-MFM-eng

October, 2008

Mass Flowmeter Model 5860E

Feature and Benefits

- Mass flow measurement
- Fast response - flow signal less than 3 seconds to 98% of final value
- $\pm 1\%$ full scale accuracy including linearity
- Flow rates (0.06 sccm through 30,000 sccm)
- Repeatability: $\pm 0.25\%$ of rate
- Linear output signal, 0-5 Vdc
- 316 L, VAR Stainless Steel
- No moving parts
- All solid state electronics
- Compact
- Removable sensor
- Insensitive to mounting attitude

Description

The Brooks® Model 5860E Mass Flowmeter accurately measures gas flow. The heart of the system is the flow sensor which produces an electrical output signal linear with mass flow rate. This signal is used for indicating and/or recording. Many options are offered to provide a versatile system of mass flow measurement.

Principle of Operation

The operating principle of the Brooks Mass Flowmeter is thermodynamic. A precision power supply directs heat to the midpoint of the sensor tube carrying a constant percentage of flow. On the same tube equidistant upstream and downstream of the heat input are resistance temperature measuring elements.

With no flow, the heat reaching each temperature element is equal. With increasing flow, the flow stream carries heat away from the upstream element, T1, and an increasing amount towards the downstream element, T2. An increasing temperature difference develops between the two elements, and this difference is proportional to the mass flow rate. A bridge circuit interprets the temperature differential and an amplifier provides the 0-5 Vdc output signal.

Specifications

Flow Ranges

Any full scale flow rate from 3 sccm* to 30 slpm, N₂
*Standard pressure and temperature in accordance with SEMI (Semiconductor Equipment and Materials Institute) standard: 0°C and 101.3 kPa (760 Torr).

Ratings

Maximum Operating Pressure: 4500 psi (31.03 MPa)
Ambient/Operating Temperature: 40°F to 150°F (5°C to 65°C)
Non-operating: -13°F to +212°F (-25°C to 100°C)



Model 5860E
Mass Flowmeter

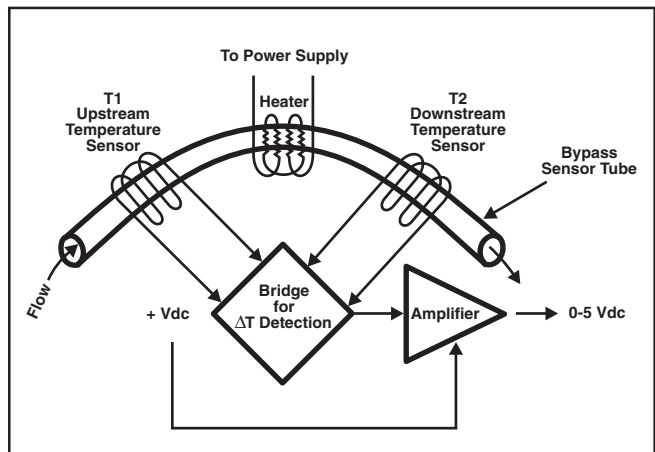

Figure 1 Principle of Operation

Performance

Accuracy: $\pm 1\%$ full scale including linearity at calibrated conditions. $\pm 1.5\%$ full scale including linearity for flow ranges greater than 20 slpm.

Repeatability

0.25% of rate

Response Time

Less than 3 seconds to within 2% of full scale of final value for a 0 to 100% flow step.

Control / Usable Range

50 to 1

Sensitivity to Mounting Attitude

$\pm 0.5\%$ F.S. maximum deviation from specified accuracy after rezeroing under 200 psig.

Model 5860E

Specifications (continued)

Temperature Sensitivity

Zero: Less than $\pm 0.075\%$ F.S. per degree C
Span: Less than $\pm 1.0\%$ F.S. shift from original calibration over 10-50°C range

Pressure Sensitivity

0.03% per PSI up to 200 PSIG

Power Supply Sensitivity

$\pm 0.09\%$ full scale per % power supply voltage variation

Output Signal

0 to 5 Vdc into 3000 ohms (or greater) load. Maximum ripple 3 mV

Leak Integrity

1×10^{-9} atmosphere scc/sec. Helium

Power Requirements

+15 Vdc ($\pm 5\%$) at 35 mA dc
-15 Vdc ($\pm 5\%$) at 35 mA dc
1.05 watts power consumption

Materials of Construction

Fittings and Transducer Assembly - Wetted parts 316 stainless steel

O-rings and Gaskets - Standard: Viton® fluoroelastomers and Buna-N; Optional: Kalrez®

Electrical Connections

D-connector, 15-pin type (DA-15P).

Dimensions

See Figure 2.

Accessories

Model 0152/54: Power Supply/Indicator (2 or 4 meters)

Filters

Open Frame Power Supplies

Ordering Information

1. Flow sensor
 - a. Type of gas to be metered
 - b. Operating temperature and pressure of gas
 - c. Flow range
 - d. Inlet and outlet connections
2. Power Supply
3. Indicator (digital)
4. With or without interconnecting cable
5. Additional accessories

Brooks Instrument

407 West Vine Street
P.O. Box 903
Hatfield, PA 19440-0903 USA
T (215) 362-3700
F (215) 362-3745
E-Mail BrooksAm@BrooksInstrument.com
www.BrooksInstrument.com

Brooks Instrument

Neonstraat 3
6718 WX Ede, Netherlands
T 31-318-549-300
F 31-318-549-309
E-Mail BrooksEu@BrooksInstrument.com

Brooks Instrument

1-4-4 Kitasuna Koto-Ku
Tokyo, 136-0073 Japan
T 011-81-3-5633-7100
F 011-81-3-5633-7101
E-Mail BrooksAs@BrooksInstrument.com

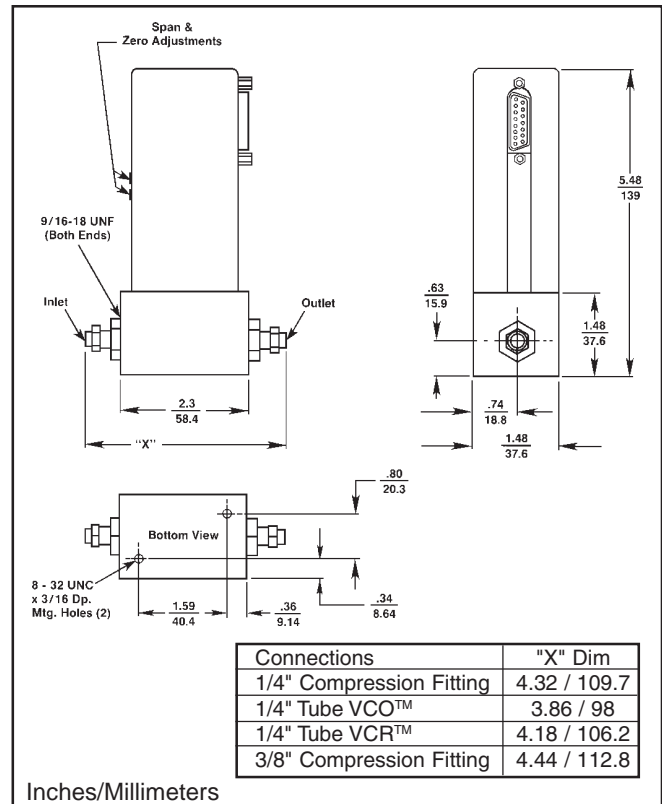

Figure 2 Dimensions Model 5860E

TRADEMARKS

Brooks Brooks Instrument, LLC
Kalrez DuPont Dow Elastomers
VCO Cajon Co.
VCR Cajon Co.
Viton DuPont Performance Elastomers

Specifications Subject to Change Without Notice

