

4800 Series

Thermal Mass Flow



Ultra-Fast Responding Mass Flow Controllers & Meters

Overview

The Brooks 4800 Series features a broad flow range, compact size, a variety of analog and digital I/O options, a MEMS-based sensor that provides lightning fast response times, and many other benefits for a variety of applications. The 4800 Series of mass flow controllers and mass flow meters is fully RoHS compliant and is an excellent choice for measurement and control of many common gases including air, N₂, O₂, Ar, He, H₂, CO₂, CO, N₂O, CH₄, C₃H₆, and C₃H₈. The optional Local Operator Interface (LOI) provides a convenient user interface to view, control, and configure the 4800 Series devices eliminating the need for remote secondary electronics.

Product Description

The 4800 Series MEMS-based sensor provides lightning fast response times.

The 4800 Series utilizes a Micro Electro Mechanical System (MEMS) based thermal sensor. Similar to typical thermal sensors, it measures a change in temperature to determine mass flow rate. The difference is that gas flows directly across the sensor, achieving extremely fast response times.

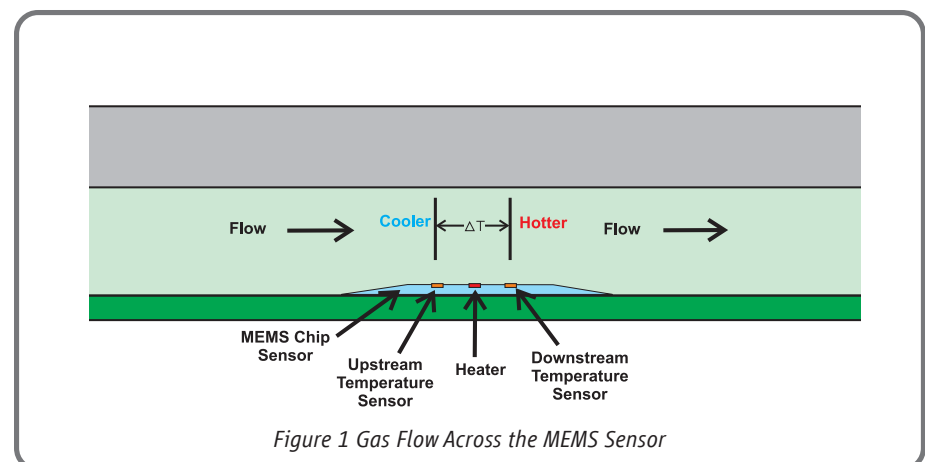

Product Description (Continued)

Fast settling times and stable control come standard with the 4850 controller.

The Model 4850 uses a proprietary PID algorithm to optimize the control valve response to ensure rapid settling times. The 4850 can be counted on to quickly match actual mass flow to any changes in setpoint.

Good things come in small packages.

The MEMS sensor enables a dramatic reduction in size compared to traditional thermal mass flow controllers and thermal mass flow meters. In fact the compact size of the 4800 Series 1" x 3" x 4" (25mm x 76mm x 101mm) takes up less than half the space of typical thermal mass flow controllers.

The 4800 Series is ideal for OEMs.

The broad flow range, fast response time, compact size and the ability to store up to nine (9) gas calibrations make for a perfect fit in any OEM system where gas flow needs to be measured or controlled.

The Local Operator Interface (LOI) simplifies set-up and operation.

The LOI mounts securely on top of the 4800 Series device. With status LEDs and a large backlit LCD it provides a convenient user interface to view, control and configure the Brooks 4800 Series thermal mass flow devices. This option also allows the user to power the device with a simple power adapter that plugs right in to the wall.

RoHS compliant

Fully RoHS compliant per EU Directive 2002/95.

Variety of input/output options.

The 4800 Series thermal mass flow controllers and thermal mass flow meters come standard with voltage or current and RS-232 I/O. These products are also available with RS-485 or Profibus digital communications.

Software and support tools

The Brooks Smart DDE (Dynamic Data Exchange) makes it easy to communicate with the 4800 Series RS-485 Digital devices. If you choose Profibus communications the GSD file is available for download. If analog I/O is selected you can download a free LabView VI to monitor and zero the device.

Easily integrated into modular gas delivery systems

The 4800 Series is available with downport connections making it easy to integrate into modular gas delivery systems.

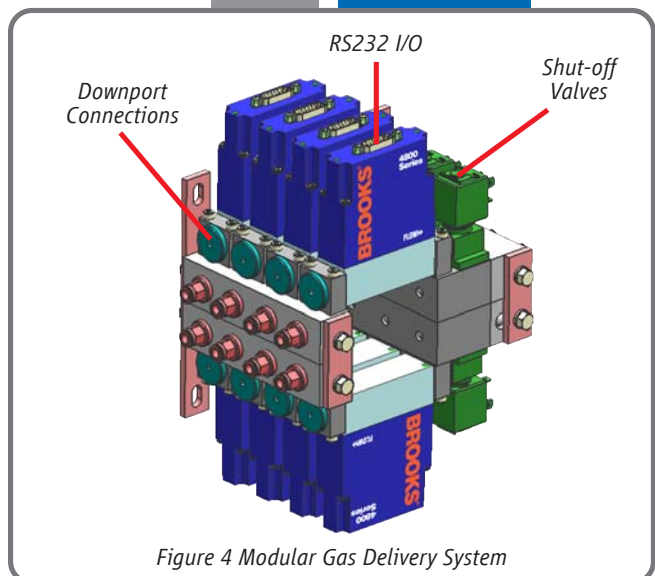
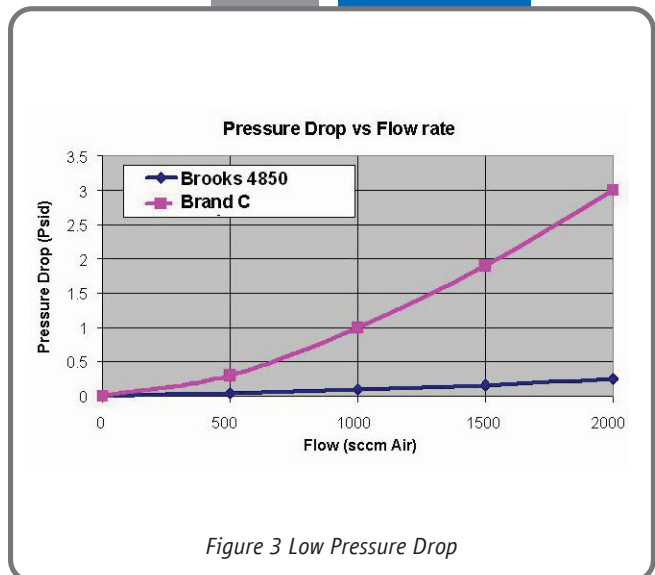
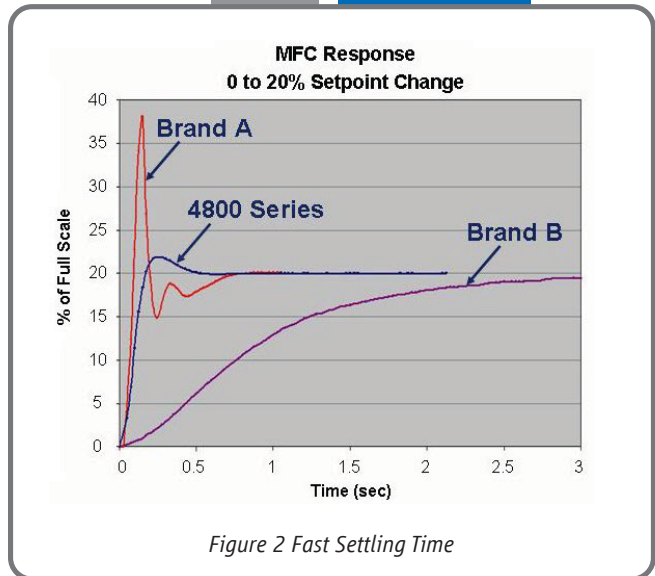



Figure 5 4800 Series with Local Operator Interface

Features and Benefits

Features	Benefits
Fast response time	Ensure rapid step during process recipe changes
Compact size	Reduces space and eases installation
Optional Local Operator Interface (LOI)	Provides a turnkey solution for local indication, set point control and device configuration eliminating the need for remote secondary electronics
Low pressure drop across the sensor	Provide flow measurement with minimal pressure budget
Variety of analog and digital I/O	Easily aligns with user requirements
Fully RoHS compliant	Meets emerging environmental requirements
Storage of up to 9 selectable gas calibrations	Provides great flexibility for the user and may provide a reduction in spares inventory

Product Applications

Heat Treating, Cutting/Welding, And Other Thermal Processes

The thermal process market is diverse, but the application demands are similar: reliable, accurate control of inert shielding gases and excellent control of O₂ and combustion gasses to ensure that the desired outcome is achieved time after time.

The Model 4850 provides an economical thermal mass flow control solution for flows up to 40 slpm. The 4800 Series utilizes a MEMS mass flow sensor designed specifically for inert and non-corrosive gasses such as those found in thermal applications.

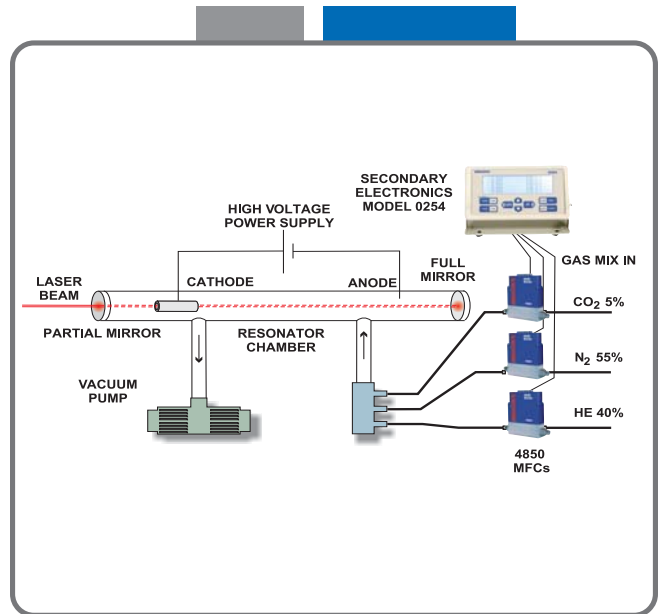

Solar / Thin Film Processing (Physical Vapor Deposition)

Physical vapor deposition or sputtering is commonly used for creating films of material, often metal, on a substrate. Plasma is used to move and accelerate the atoms of interest toward the target placed in a vacuum chamber. Mass flow controllers are used to control the gas flow to the chamber. Our advanced control valve PID controller can eliminate overshoot that can quench and destabilize the plasma.

The Brooks 4800 Series is a great solution for controlling argon in a plasma process. This product has a very fast response to setpoint without overshoot along with having a very small footprint.

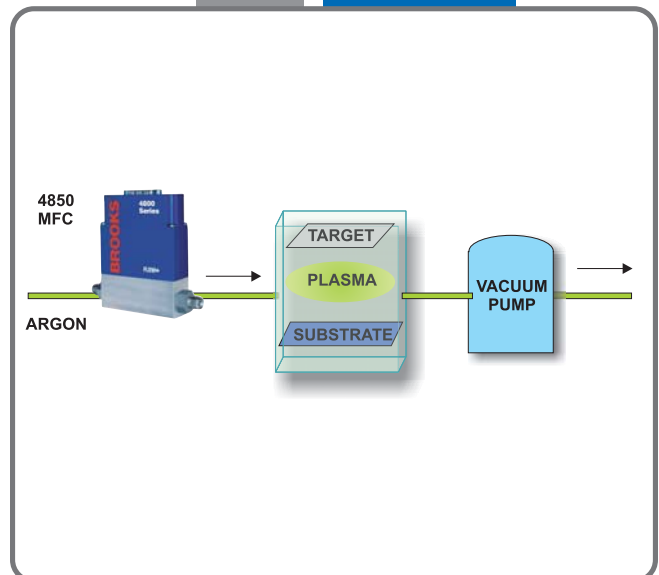

Analytical OEM

Analytical OEMs need to measure and control reagent, calibration and sample gas flows. These applications often require that the flow control device have small physical size, low pressure drop, excellent repeatability and be easy to integrate into their system. The Brooks 4800 Series provides all this and much more. The Model 4850 mass flow controller can store multiple gas calibrations to reduce spares and inventory requirements. This product can also be private labeled for specific OEM requirements.

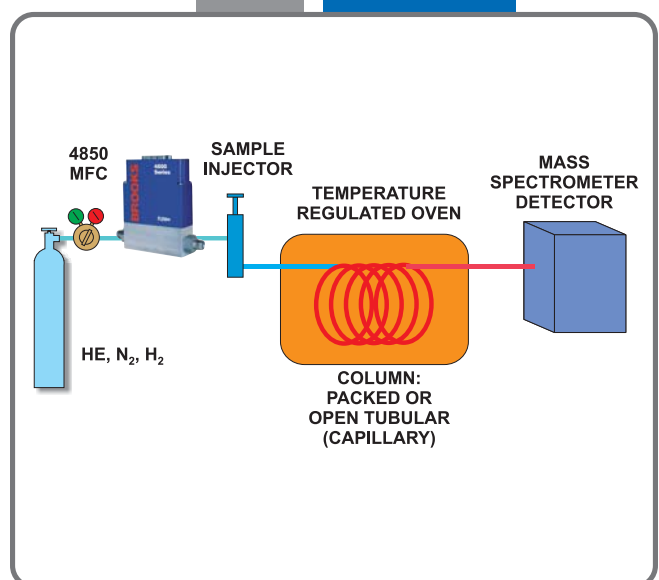

Product Specifications

Performance

Full Scale Flow Range	50 ml/min - 40 l/min
	(50 sccm - 40 slpm)
	(N ₂ eq., at 0°C Ref)
Control Range	2 - 100%
Flow Accuracy	+/- 3.0% of FS, +/- 1.0% FS optional
Flow Repeatability	+/- 0.15% of FS
Response Time	Flow signal: <0.3 sec Flow control: Settling time <0.75 sec from 0 to 100% FS (typical <0.5 sec for all steps)
Temperature Coefficient	+/- 0.1% of FS/°C (N ₂)

Ratings

Gases	Air, N ₂ , O ₂ , Ar, He, CO ₂ , CO, N ₂ O, CH ₄ , C ₃ H ₆ , C ₃ H ₈ (other gases upon request)
Operating Limits	Pressure 0 - 10 barg (0 - 150 psig)
	Temperature 0 - 50°C
	Humidity 5 to 95% R.H. (ambient)
Differential Pressure Range (Controllers)	Minimum: 0.35 bar (5 psid) Maximum: 10 bar (150 psid)
Leak Integrity	Inboard to Outboard: 1x10 ⁻⁹ atm scc/sec Helium max.

Mechanical

Materials of Construction	Wetted parts: stainless steel, fluoroelastomers, silicon-based sensor
RoHS	Fully RoHS compliant per EU Directive 2002/95.
Outline Dimensions	Refer to Figures 6 through 10
Process Connections	Inlet/Outlet threads: 9/16" - 18 UNF threads, Refer to Figures 6, 9 and 10 for available process connections.

Electrical

Electrical Connections	15-pin D-sub connector Analog/RS-485: Profibus option: 9-pin female D-sub connector for signal and an M5 connector for power.			
Power Supply Voltage**	+15 Vdc + 10% or +24 Vdc + 10% Device only uses single sided power supply Inrush current: < 1 A			
Power Requirements	Model	Device	15 Vdc	
		Type	Typical (mA)	Max (mA)
	4850	Controller	130	160
	4860	Meter	30	60
Analog Input/Output	0-5 Vdc or 4-20 mA			
Digital Input/Output	RS-232 (Standard with all analog I/O options) RS-485 (S-Protocol) Profibus (Both DPV0 and DPV1 are supported)			
Valve Override Signal	Valve Controller: Input Open Valve Closed: <0.3 V; open valve: >4.8 V			
Calibration Curve Selection	Select one of nine gases via the LOI or RS232. Optional software tool for ease of RS232 connection is available on the Brooks Instrument website. Contact your local Brooks representative or the factory for details and cable options.			

** For high flows and/or low differential pressures (using orifices 0.049" (1.25mm) or 0.079" (2.0mm)) only 24 Vdc power is available.

Local Operator Interface (LOI)

Display	Effective display area: 28mm wide, 11mm high Display Contents: 8x2 dot matrix display	
Operating Limits	Temperature	0-50°C
	Operating Humidity	5 to 95% R.H. (ambient)
Electrical Connections	2 15-pin D-sub connectors, one for the connection to the 4800 Series and one for the remote connection	
Power Supply Voltage	The LOI optionally includes a wall mount power adaptor with a 3.5-mm DC-plug. The adaptor works with input voltages of AC 90-240 V/47-63Hz. The adaptor supports European, U.K., Australia and U.S. wall plugs. Power can also be supplied by a remote connection via the D-connector.	
Materials of Construction	Enclosure: ABS plastic with CU-Ni plating	
RoHS	Fully RoHS compliant per EU Directive 2002/95.	
Outline Dimensions	Refer to Figure 8	

Product Dimensions

15 Pin D-Sub Connector

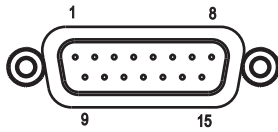

15 Pin D-Sub Connector

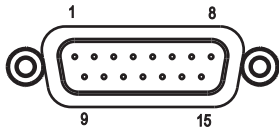

9 Pin D-Sub Connector and Power Connection

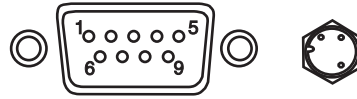

PIN#	4800 Series / LOI	PIN#	RS-485 Module	PIN#	Profibus Module Signal
1	Setpoint Signal Common	1	Setpoint Signal Common	1	Shield
2	Flow Voltage Output	2	Flow Voltage Output	2	Not used
3	Not used	3	Alarm Output	3	RXD / TXD - B - red wire
4	Flow Current Output	4	Flow Current Output	4	Not used
5	Positive Supply Voltage	5	Positive Supply Voltage	5	Common
6	Not used	6	Not used	6	+5 Vdc
7	Setpoint Current Input	7	Setpoint Current Input	7	Not used
8	Setpoint Voltage Input	8	Setpoint Voltage Input	8	RXD / TXD - A - green wire
9	Power Supply Common	9	Power Supply Common	9	Not used
10	Flow Signal Common	10	Flow Signal Common		
11	Not used	11	Not Used	PIN#	Profibus Module Power
12	Valve Override Input	12	Valve Override Input	1	+24 Vdc
13	Not used	13	Not Used	2	Not used
14	RXD	14	RXD / A-	3	Common
15	TXD	15	TXD / +	4	Not Used

Table 1 4800 Series Pin-Out Diagram

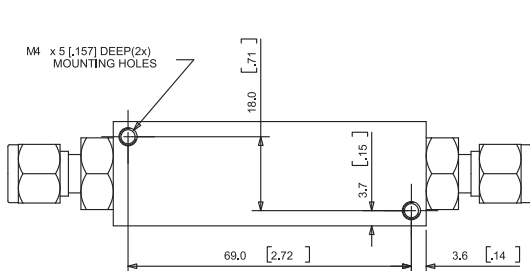
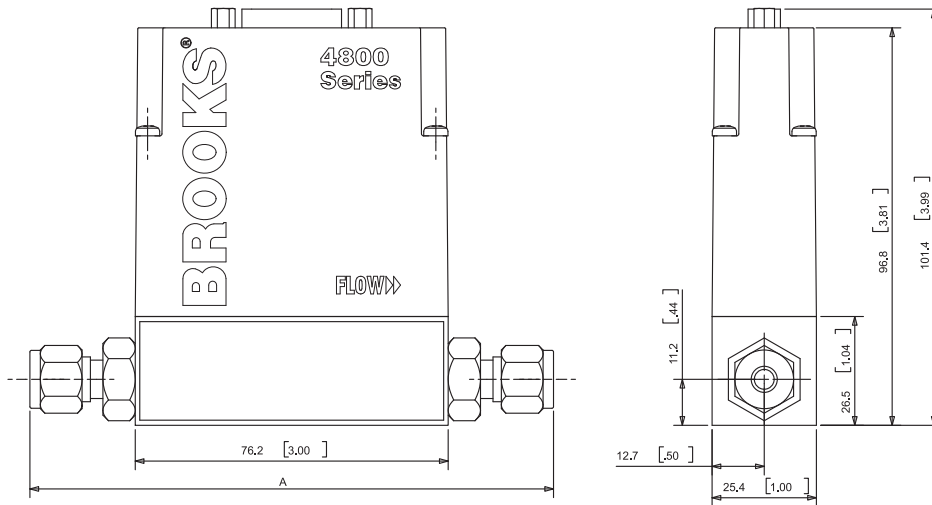

CONNECTIONS	A
1/4" TUBE COMPRESSION	127.5 [5.02"]
1/8" TUBE COMPRESSION	122.9 [4.84"]
3/8" TUBE COMPRESSION	130.6 [5.14"]
1/4" VCO	115.8 [4.56"]
1/4" VCR	124.0 [4.88"]
1/4" NPT-F	116.4 [4.58"]
1/4" Rc-F	116.4 [4.58"]
6mm TUBE COMPRESSION	127.6 [5.02"]
10mm TUBE COMPRESSION	131.0 [5.16"]
1/4" TUBE COMPRESSION FOR 5850TR REPLACEMENT	128.8 [5.07"]

mm [inches]

Figure 6 Dimensions for 4800 Series Devices with Standard Process Connections

Product Dimensions

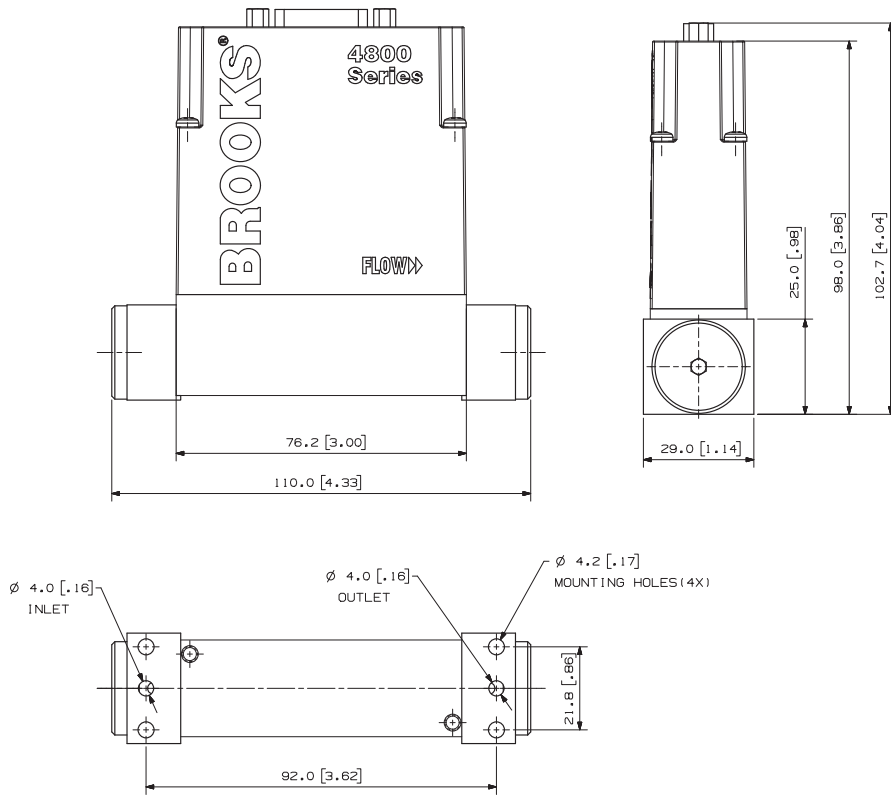

Figure 7 Dimensions for 4800 Series Devices with Downport Connections

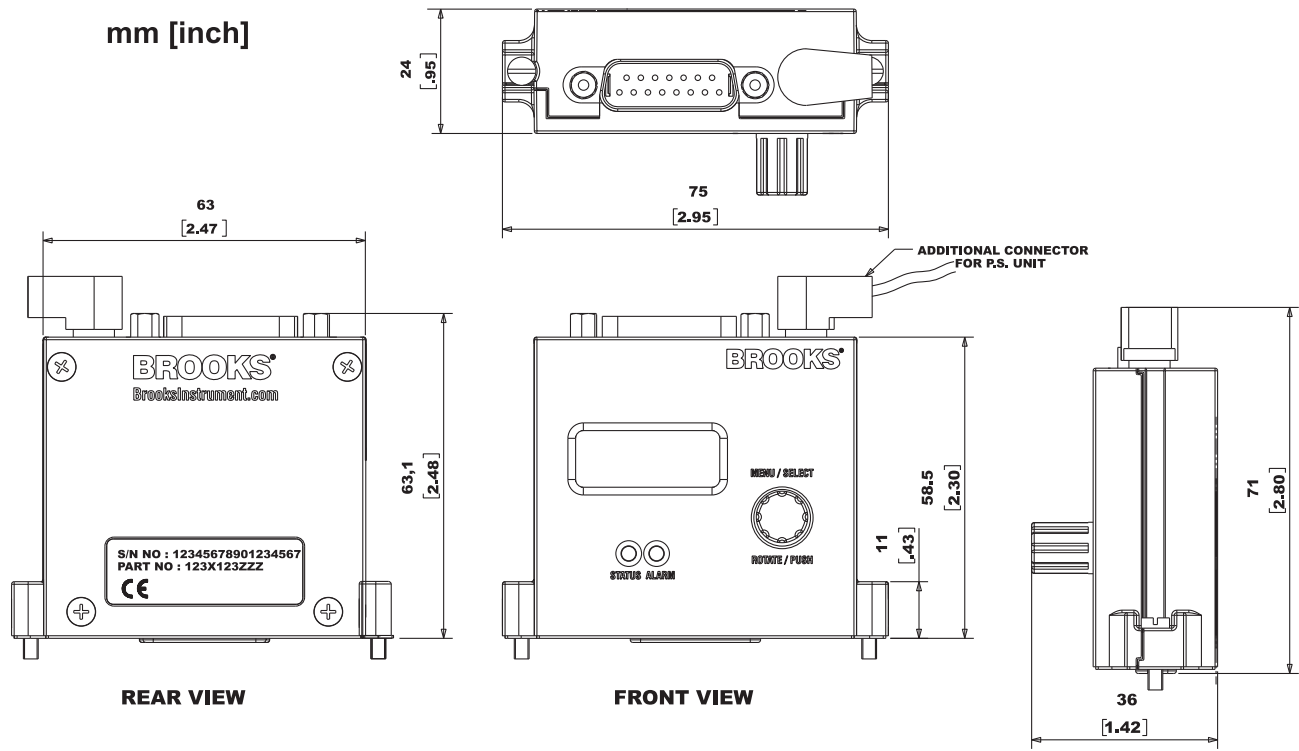
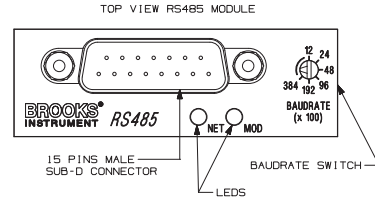
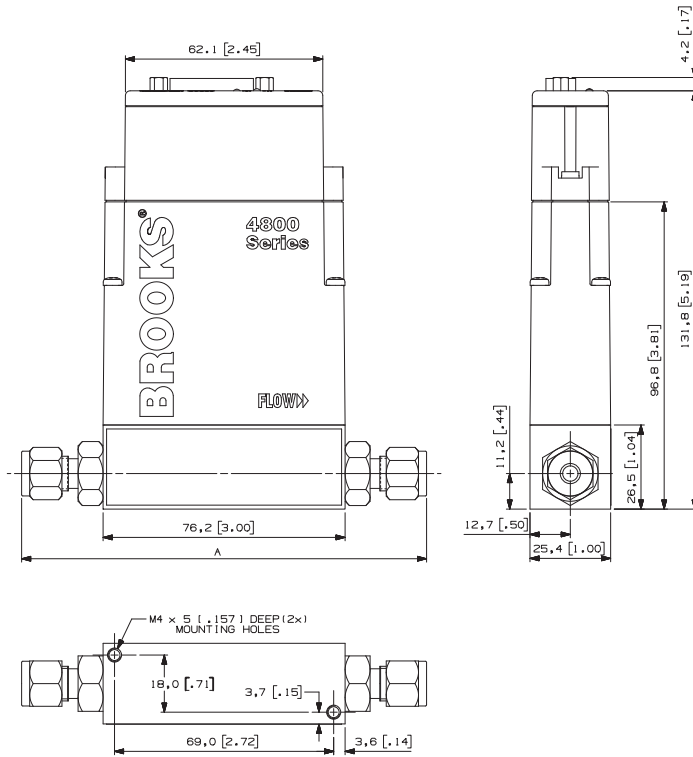

Figure 8 Dimensions for 4800 Series LOI Module

Product Dimensions



CONNECTIONS	A
1/4" TUBE COMPRESSION	127.5 [5.02"]
1/8" TUBE COMPRESSION	122.9 [4.84"]
3/8" TUBE COMPRESSION	130.6 [5.14"]
1/4" VCO	115.8 [4.56"]
1/4" VCR	124.0 [4.88"]
1/4" NPT-F	116.4 [4.58"]
1/4" Rc-F	116.4 [4.58"]
6mm TUBE COMPRESSION	127.6 [5.02"]
10mm TUBE COMPRESSION	131.0 [5.16"]
1/4" TUBE COMPRESSION FOR 5850TR REPLACEMENT	128.8 [5.07"]

mm [inches]

Figure 9 Dimensions for 4800 Series RS-485 Module

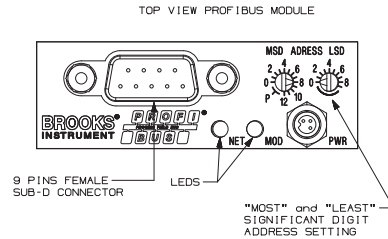
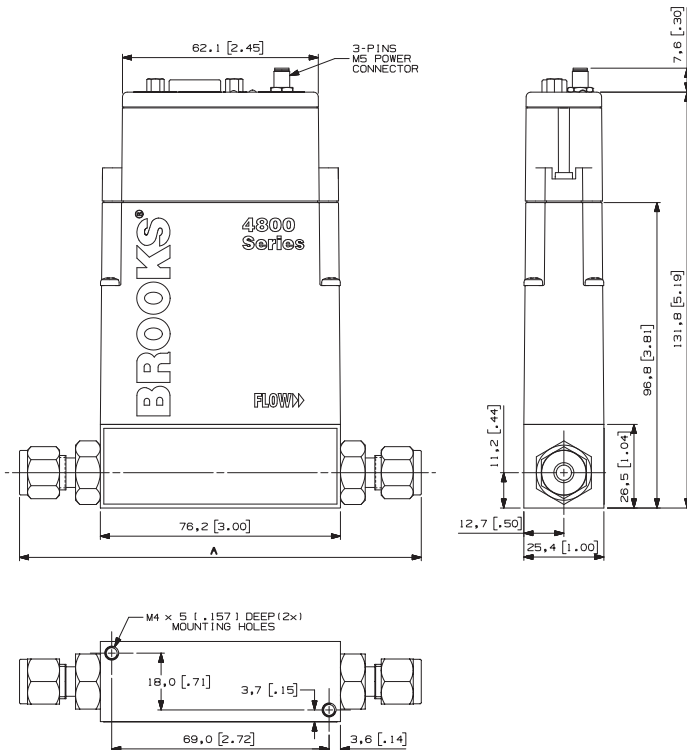

CONNECTIONS	A
1/4" TUBE COMPRESSION	127.5 [5.02"]
1/8" TUBE COMPRESSION	122.9 [4.84"]
3/8" TUBE COMPRESSION	130.6 [5.14"]
1/4" VCO	115.8 [4.56"]
1/4" VCR	124.0 [4.88"]
1/4" NPT-F	116.4 [4.58"]
1/4" Rc-F	116.4 [4.58"]
6mm TUBE COMPRESSION	127.6 [5.02"]
10mm TUBE COMPRESSION	131.0 [5.16"]
1/4" TUBE COMPRESSION FOR 5850TR REPLACEMENT	128.8 [5.07"]

mm [inches]

Figure 10 Dimensions for Model 4800 Series Profibus Module

Product Certifications

These certifications cover the 4800 Series thermal mass flow devices as well as the Local Operator Interface (LOI), the Profibus digital interface module and the RS-485 digital interface module.

EMC Directive 2004/108/EC: per EN 61326:2006

Hazardous Location Classification

The modules shall be installed in a suitable enclosure providing a degree of protection of at least IP54 according to EN 60529, taking into account the environmental conditions under which the equipment will be used. Provisions shall be made to prevent the rated voltage from being exceeded by transient disturbances of more than 40%.

Enclosure: Type 1/IP40

Ambient Temperature:

$0^{\circ}\text{C} \geq T_{\text{amb}} \leq 50^{\circ}\text{C}$ ($32^{\circ}\text{F} \geq T_{\text{amb}} \leq 122^{\circ}\text{F}$)

United States and Canada



Non-Incendive
Class 1, Division 2
Groups A, B, C&D; T4

150464

Per UL 1604 and CSA-C22.2 no. 213-m87

Class 1, Zone 2, AEx nA II T4

Per ANSI/ISA 12.12.02 - 2003 and ANSI/UL 60079-15

Ex nA II T4

Per CSA - E79-15

Europe - ATEX Directive 94/9/EC

KEMA 06ATEX0251 per EN 60079-15: 2003



II 3 G EEx nA II T4



Pressure Equipment Directive (97/23/EC):

Sound Engineering Practice

Model Code

Code Description	Code Option	Option Description			
I. Base Model Number	4850	Flow Controller, Body 0 (50 sccm-40 slpm)			
	4860	Flow Meter, Body 0 (50 sccm-40 slpm)			
II. Digital I/O Communications	A	RS-232 + Analog, Select applicable analog I/O			
	P	Profibus DPV1, Select analog I/O = 0 (none)			
	S	RS-485 (Smart), Select applicable analog I/O			
III. Model Revision Level	B	Revision			
IV. Analog I/O, Input / Output	B	0-5 Vdc / 0-5 Vdc			
	C	4-20 mA / 4-20 mA			
	D	0-5 Vdc / 4-20 mA			
	E	4-20 mA / 0-5 Vdc			
	0	None			
V. Power Supply	1	15 Vdc			
	2	24 Vdc			
VI. Mechanical Connections	1A	9/16" -18unf straight thread			
	B1	1/4" tube compression w/filter			
	C1	1/8" tube compression w/filter			
	D1	3/8" tube compression w/filter			
	E1	1/4" VCR w/filter			
	F1	1/4" VCO w/filter			
	G1	1/4" NPT-F w/filter			
	H1	6mm tube compression w/filter			
	J1	10mm tube compression w/filter			
	S1	Downport, no O-ring cavity			
	T1	1/4" Rc (BSPT) w/filter			
	X1	Downport, with O-ring cavity			
Y1	1/4" tube w/filter (5850TR replace)				
VII. Body		Body	O-Ring Seal	Seat	Valve Type
	A	316ss	Viton	None (Meter Only)	None (Meter Only)
	B	316ss	Viton	Viton	Normally Closed
VIII. Area Classification	1	Standard Location (Safe Area)			
	2	ATEX Zone 2			
	4	CSA Div 2/Zone 2 (Recognized)			
IX. Valve Orifice Size	A	No Orifice (Meter Only)			
	B	0.001 inch / 0.03mm			
	C	0.002 inch / 0.05mm			
	D	0.003 inch / 0.08mm			
	E	0.005 inch / 0.125mm			
	F	0.008 inch / 0.2mm			
	G	0.012 inch / 0.315mm			
	H	0.020 inch / 0.5mm			
	J	0.031 inch / 0.8mm			
	K	0.049 inch / 1.25mm only available with power supply option code=2 (24 Vdc)			
	M	0.079 inch / 2.0mm only available with power supply option code=2 (24 Vdc)			

Model Code

Code Description	Code Option	Option Description		
X. Mass Flow Restrictor Type		Type or Restrictor	Restrictor Range (sccm N₂ Equivalent @ 0 Deg C ref)	
	A	No Restrictor	NA	NA
	C	Plug	0	180
	K	K	160.4	228.53
	M	M	218.4	310.6
	N	N	265.7	377.7
	P	P	332	471.6
	Q	Q	424.8	603
	R	R	554.8	787
	S	S	736.7	1044.6
	T	T	991.4	1405
	U	U	1348	1910
	V	V	1847	2617
	W	W	2546	3607
	X	X	3524	4992
	Y	Y	4894	6932
	1	1	6811	9647
2	2	9496	13,453	
3	3	13,250	18,773	
4	4	18,520	30,143	
5	5	30,100	50,143	
XI. Calibration		Calibration Condition	Accuracy	Tracability
	A	None-Uncalibrated	NA	NA
	B	Single Gas	+/- 3.0% of FS	None
	C	Single Gas	+/- 1.0% of FS	None
	D	Single Gas	+/- 3.0% of FS	NIST
	E	Single Gas	+/- 3.0% of FS	CMC Cert. (NMI)
	F	Multiple Gas-2nd line item req'd (price Each)	+/- 3.0% of FS	None
	G	Multiple Gas-2nd line item req'd (price Each)	+/- 1.0% of FS	None
	H	Multiple Gas-2nd line item req'd (price Each)	+/- 1.0% of FS	NIST
J	Multiple Gas-2nd line item req'd (price Each)	+/- 1.0% of FS	CMC Cert. (NMI)	
XII. Accessories	0	None		
	1	LOI with Power Adapter		
	2	LOI without Power Adapter		
XIII. Certificates	0	None		
	9	Multiple Certs. Describe required certs in notes. Add all applicable changes to list price.		
	A	Declaration of Compliance 2.1 (Certificate of Conformance)		
	B	Declaration of Compliance 2.1 Leak Test		
	C	Declaration of Compliance 2.1 Pressure Test		
	D	Declaration of Compliance 2.1 Oxygen Service		
E	Declaration of Compliance 2.1 Materials			
XIV. OEM Code	A	Standard Brooks Label		

Sample Model Code

I	II	III	IV	V	VI	VII	VIII	IX	X	XI	XII	XIII	XIV
4850	A	B	B	1	1A	A	2	D	K	E	2	9	A

Brooks Service and Support

Brooks is committed to assuring all of our customers receive the ideal flow solution for their application, along with outstanding service and support to back it up. We operate first class repair facilities located around the world to provide rapid response and support. Each location utilizes primary standard calibration equipment to ensure accuracy and reliability for repairs and recalibration and is certified by our local Weights and Measures Authorities and traceable to the relevant International Standards.

Visit www.BrooksInstrument.com to locate the service location nearest to you.

START-UP SERVICE AND IN-SITU CALIBRATION

Brooks Instrument can provide start-up service prior to operation when required. For some process applications, where ISO-9001 Quality Certification is important, it is mandatory to verify and/or (re)calibrate the products periodically. In many cases this service can be provided under in-situ conditions, and the results will be traceable to the relevant international quality standards.

CUSTOMER SEMINARS AND TRAINING

Brooks Instrument can provide customer seminars and dedicated training to engineers, end users, and maintenance persons.

Please contact your nearest sales representative for more details.

HELP DESK

In case you need technical assistance:

Americas ☎ 1 888 554 FLOW
Europe ☎ +31 (0) 318 549 290
Asia ☎ +81 (0) 3 5633 7100

Due to Brooks Instrument's commitment to continuous improvement of our products, all specifications are subject to change without notice.

TRADEMARKS

Brooks Brooks Instrument, LLC
Profibus PROFIBUS International
LabView IV National Instruments
VCO Cajon Co.
VCR Cajon Co.
Viton DuPont Performance Elastomers

DS-TMF-4800-MFC-eng (0709)



Brooks Instrument
407 West Vine Street
P.O. Box 903
Hatfield, PA 19440-0903 USA
T (215) 362 3700
F (215) 362 3745
E-Mail BrooksAm@BrooksInstrument.com
www.BrooksInstrument.com

Brooks Instrument
Neonstraat 3
6718 WX Ede, Netherlands
T +31 (0) 318 549 300
F +31 (0) 318 549 309
E-Mail BrooksEu@BrooksInstrument.com

Brooks Instrument
1-4-4 Kitasuna Koto-Ku
Tokyo, 136-0073 Japan
T +81 (0) 3 5633 7100
F +81 (0) 3 5633 7101
E-Mail BrooksAs@BrooksInstrument.com