

Data Sheet

DS-TMF-MfS-MFC-eng

April, 2008

Models MF50S-MF64S

Brooks® Mf Series Smart Mass Flow Meters and Controllers

- Provides mass flow measurement and control of gases from 3 ml_n/min. full scale to more than 2000 m³_n/h. (max. 2500 l_n/min control).
- Robust and compact.
- Weatherproof IP 65 and NEMA 4X protection.
- Certified for CE and zone 2 hazardous environment.
- Thousands of Brooks Smart Mass Flow Meters and Controllers have been installed and operate successfully in a variety of industries under various process conditions.
- Designed, developed, manufactured and supplied by the first ISO-9001 Quality Certified M&C company in the world: Brooks Instrument.
- Smart technology, available with selectable analogue I/O's and digital communication (HART based) via RS-232, RS-485 or Profibus-DP.



Brooks Smart Mass Flow Controller, model MF 50S

OUR FEATURES

- Highly accurate
- Adaptive control algorithm conditions
- Fastest flow response and output signal(s) responses
- Both analogue I/O's and digital communication
- Self draining construction corrosive fluids
- Continuous self-diagnostics
- Certified for use in zone 2
- KEMA 98ATEX4887

 II 3 GD T 85 °C EEx nV II T4

YOUR BENEFITS

- Assured process repeatability
- Unrivalled performance under varying process conditions
- Configurable and fast actual flow settling time conditions
- Easy installation, (re)configurable when needed
- Can even be hose washed down with water and mildly corrosive fluids
- Reduced maintenance and long-term reliability
- Increased safety, protected against non-authorized handling

INTRODUCTION

The weatherproof MF series MF 50S - MF 64S is based around the concept of the well proven Brooks Smart Mass Flow Meters and Controllers, series 5850S - 5864S. Thousands of these Brooks Smart Mass Flow products have been installed and operate successfully in a variety of industries even under severe conditions.

Now specially designed for Biotech and many applications for outdoor usage, the new weatherproof series MF 50S - MF 64S can also be used in hazardous areas, certified for usage in zone 2.

All Smart Mass Flow Controllers are provided with adaptive control algorithm to ensure unrivalled performance and fast control even under varying process conditions. Unsurpassed control settling time, no dead time and other features are enhanced specifications, which are listed in this new product data sheet.

Our commitment to continuous improvement in terms of specification, safety standards and application flexibility, make these Brooks Smart Mass Flow Products leaders throughout industry.

Brooks Instrument excels in terms of performance, features, reliability, serviceability and overall perceived quality.

Various calibration gases are available at Brooks Instrument to simulate difficult process applications. From the beginning, the Smart Mass Flow Products were designed with user safety as one of the most important criteria. The Smart electronics are protected against non-authorized handling.

FIELD PROVEN PERFORMANCE AND RELIABILITY

- IP 65 and NEMA 4X Weatherproof protected and resistant to hose wash downs with water and mildly corrosive fluids.
- Certified for safe use in zone 2. Environment according to pr EN 50021:1998 and EN 50281-1-1:1998.
- CE certified.
- Microprocessor-based, smart electronics.
- Robust adaptive control provides rapid response to varying process conditions, including temperature and pressure changes.
- Analogue I/O and digital communication; via RS-232 point-to-point transmission, RS-485 multi-point interconnection or Profibus-DP.
- Continuous self-diagnostics for maximum reliability.
- More than 200.000 previous generation models installed & operational worldwide.

FLEXIBILITY

- Designed for easy installation
- Wide range power supply
- Selectable analogue setpoint input/flowrate output signals

- Totalizer function
- Digital communication up to 38k4 Baud transmission speed selectable 12 Baud for Profibus-DP
- Self diagnostics and alarm functions via hardware and/or software
- Up to ten (10) sets of different calibration curves programmable
- Wide flow & pressure range

The models are:

Brooks Smart Mass Flow Products				
Mass Flow Controller	Mass Flow Meter	Flow Ranges		
Model:	Model	Min. f.s.	Max. f.s.	Unit
MF50S	MF60S	0,003	30	ln/min
MF51S	MF61S	20	100	ln/min
MF53S	MF63S	100	2500	ln/min
	MF64S	18	2160	m ³ _n /h

PERFORMANCE

Digital communication, via RS485 or RS232, provides access to all of the Smart DMFC's functions, including:

- Accurate Mass Flow measurement and setpoint regulation (controller only), as a percentage and in selectable engineering units.
- Flow totalizer.
- Temperature.
- Operational settings.
 - Calibration (storage of up to 10 cal. curves)
 - PID control setting
 - fast response
 - 'traditional' soft start
 - linear ramp-up/down characteristic
 - adaptive valve control
 - Adaptive filtering for signal flow component
- Alarms.
 - Self-diagnostic
 - EEPROM error
 - database error
 - analogue output error
 - Out-of-range indications for
 - setpoint
 - flow
 - valve
 - analogue output
 - Environmental errors
 - no gas flow detected
 - power supply outside spec. range
 - ambient temp. outside spec. range
 - high and low flow alarms

SERVICEABILITY

The Brooks Smart Mass Flow Meters and Controllers perform continuous self diagnostic routines that immediately identify any problem in the device, the process or the environment. The process variables gas flow, temperature and also environmental variables like sensor, control valve and power supply values are continuously monitored.

An alarm situation in detail can be visualised on a screen (by means of digital communication). It is always available as an open collector output signal.

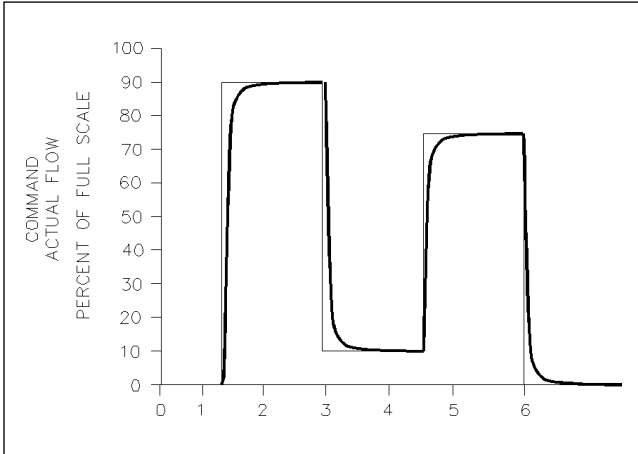

Figure 1: The Response Performance of the Brooks Smart Mass Flow Controllers

BROOKS SMART MASS FLOW CONTROLLERS FAST RESPONSE PERFORMANCE

The curves in Figure 1 depict the M.F.C. output signal and actual transitional flow to steady-state when gas flow enters into a process chamber, under a step response command condition.

Adaptive (optimized) PID control, including fast response to 0.2 sec. and linear ramp-up and/or ramp-down control characteristics.

SELECTABLE VALVE OVERRIDE

Gas handling safety practices must be given consideration in many processes. Since M.F.C.'s are an integral part of many gas systems, it was mandatory to include these practices in the Brooks Smart Mass Flow Controllers' design standards. Independent of command setpoint values the control valve can be fully opened or closed via the valve override feature by simply providing a voltage signal through the interconnection wiring or through digital communication (analogue input overrides digital). This is useful for shutdown or system purge requirements.

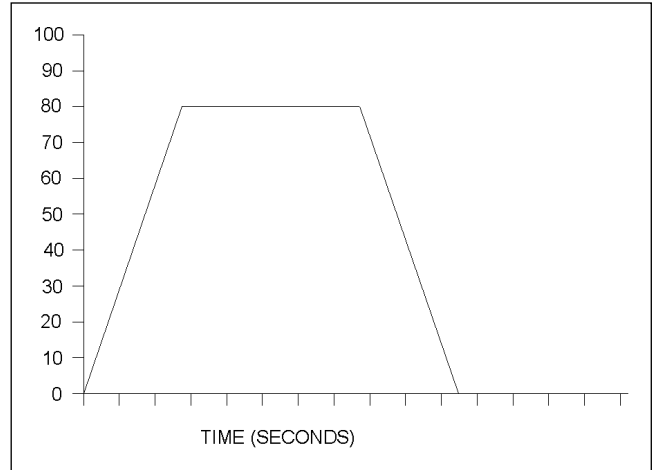

Figure 2: Linear ramp-up and/or ramp-down from 200% second down to 0.5% per second setpoint change

SELECTABLE SOFT START

Processes requiring injection of gases can be adversely affected by excessive initial gas flow. This abrupt injection of gas can result in process damage from explosion or initial pressure impact. These problems are virtually eliminated with the soft start feature.

Traditional soft start or linear ramp up and/or ramp down (see figure 2) can be factory selected or are available via the Operator Interface.

Linear ramping is adjustable from 200% per second down to 0.1% per second setpoint change. (To be specified at ordering).

AVAILABLE OPTIONS

- The Brooks Smart Mass Flow Meters and Controllers (DMFC) are always available with analogue I/O setting. The models 0152/0154 offer a power supply, read out, control independently or in blending mode and other features (fig. 1). More details wanted? Ask for our Product Data Sheet 0152/0154.
- Standard also suitable for digital communication (either via RS-232 or RS-485) which allows you to also use our Smart Control, model 0160, for user interface function and (re)configuration purposes of the Smart Mass Flow Products. More details wanted? Ask for our Product Data Sheet 0160.
- The Smart DDE, model 0162 is a reliable Dynamic Data Exchange software product from Brooks Instrument. It allows you to make bi-directional links between your Windows-based applications and the Brooks Smart Mass Flow Products (fig. 2 and 3). More details wanted? Ask for our Product Data Sheet 0162.

TYPICAL INSTALLATIONS FOR ANALOGUE AND DIGITAL (RS-232) SET-UP

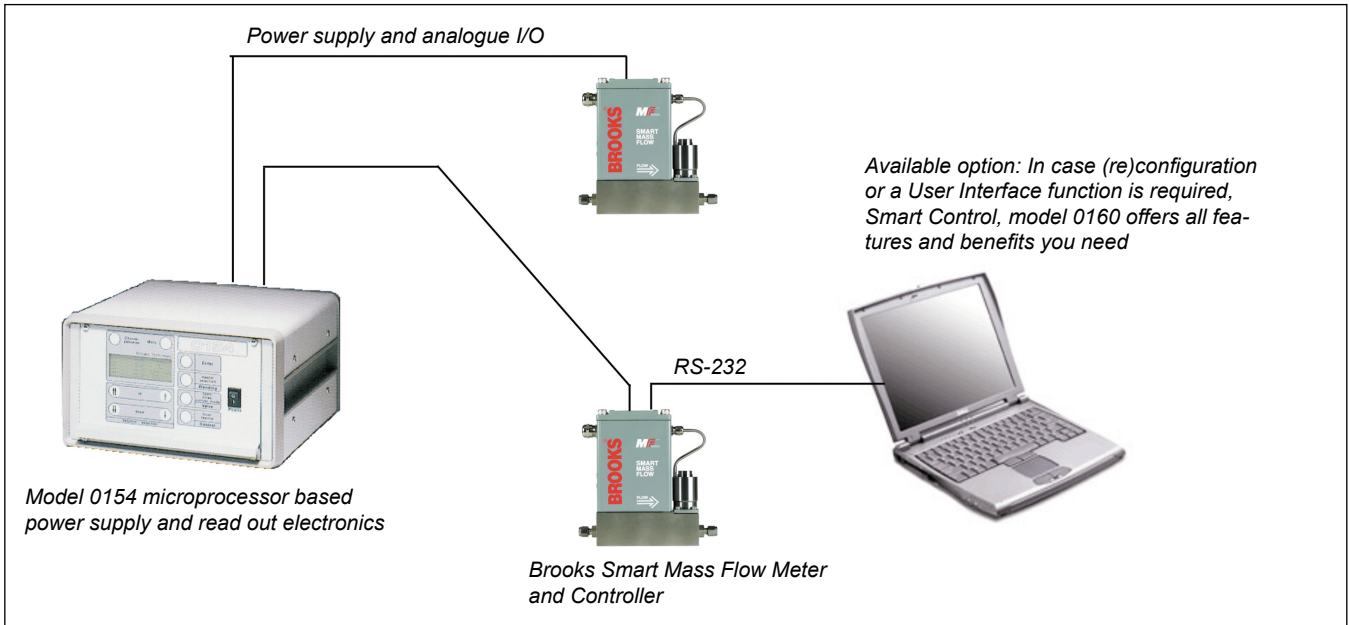

Figure 3

Brooks Smart (DMFC) Mass Flow Meters and Controllers multi-channel, analogue I/O's operated by model 0154. The model 0154 microprocessor based electronics, provides power supply and analogue I/O to the DMFC's.

(In addition, a number of other functions are standard available). Please note that digital communication via RS-232 point-to-point transmission or RS-485 multi-point interconnection are available in case of (re) configuration, or other user interface purposes.

TYPICAL INSTALLATIONS FOR DIGITAL (RS-485) SET-UP

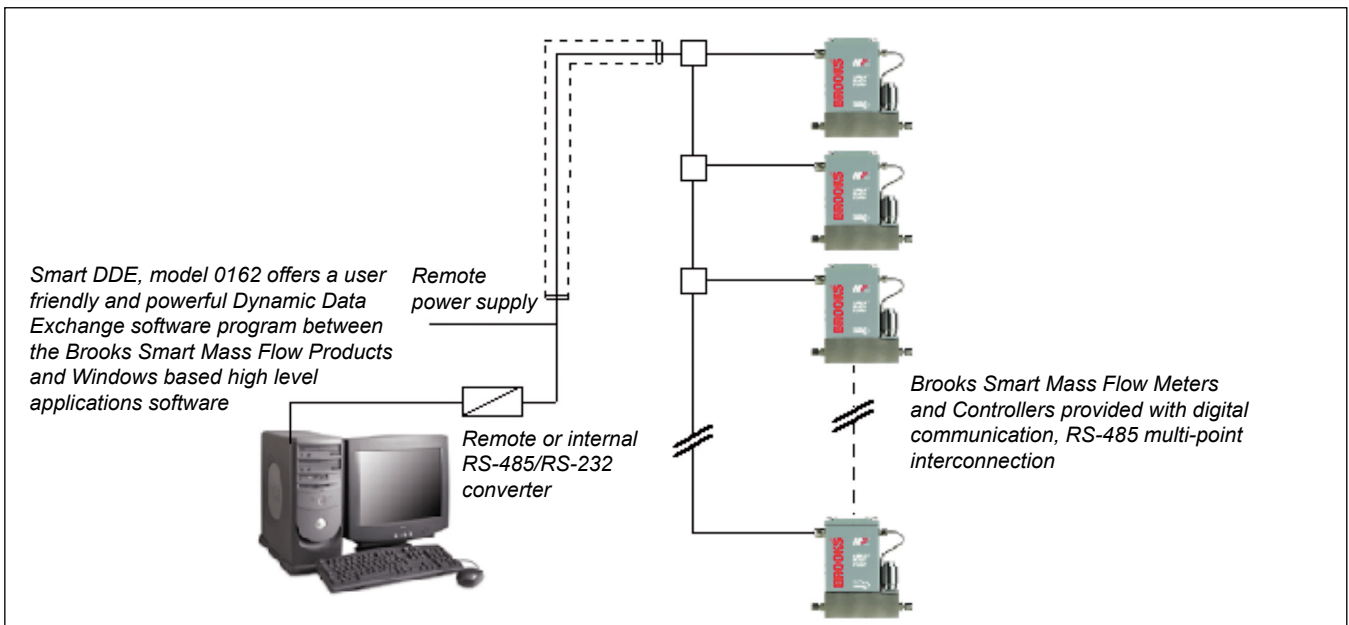

Figure 4

Multi-channel, p.c. system operated configuration with virtually unlimited number of connected Brooks Smart Mass Flow Meters and Controllers. A (remote) power supply and multi-point inter-

connection can drive up to 32 devices per COM port. With help of our Smart DDE, COM 1...COM 9 are selectable.

TYPICAL PROCESS CONTROL APPLICATIONS

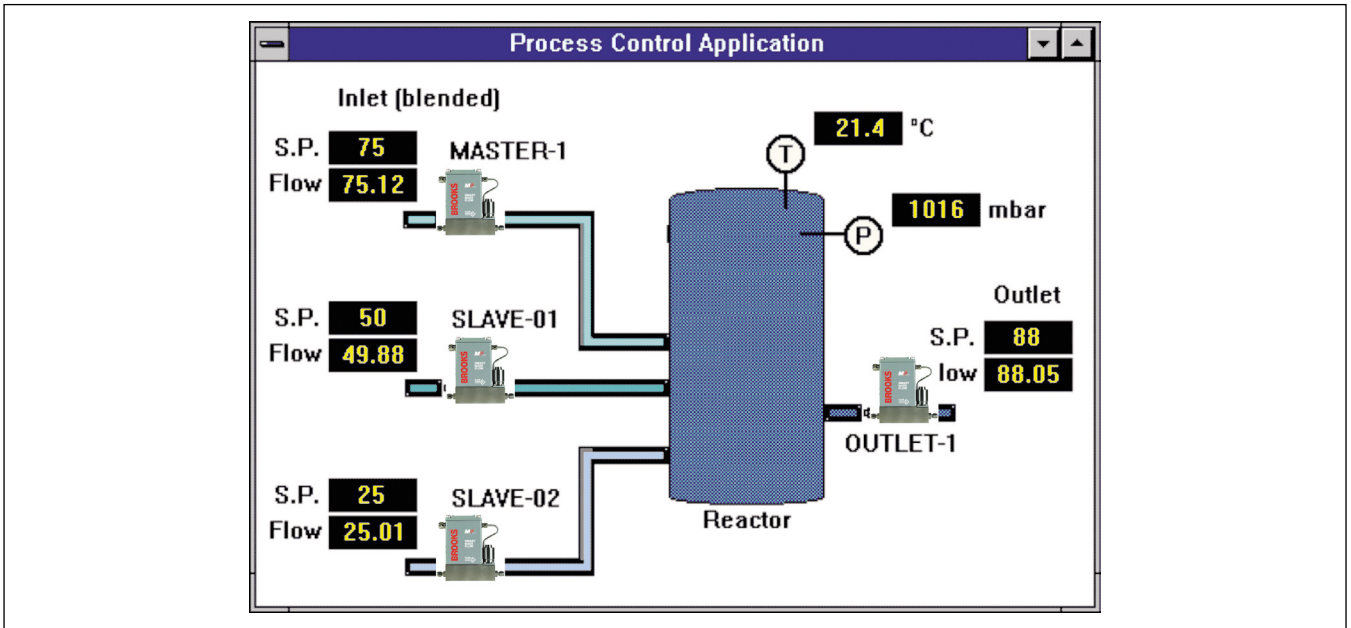

Figure 5: Any Windows based programs can be used to link information via Smart DDE, model 0162 bi-directionally to the Brooks Smart Mass Flow Products

TYPICAL INSTALLATIONS FOR PROFIBUS-DP

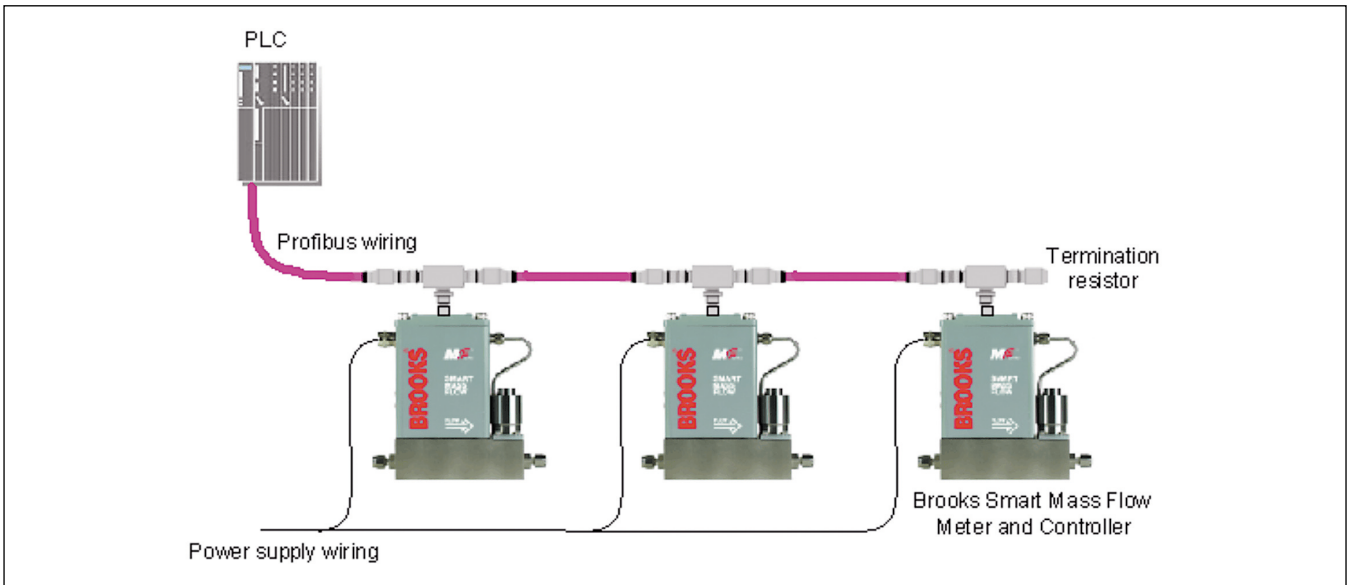

Figure 6

The Smart Mass Flow products of Brooks offer PROFIBUS-DP digital communication (high speed) capabilities AND analogue I/O signal simultaneously available. When using PROFIBUS-DP, you can connect other actuators and sensors to the same bus. I.E. saving cost (fig. 6).

PERFORMANCE SPECIFICATIONS

Flow Accuracy ± 0.7% of rate and ± 0.2% f.s. at calibration conditions or ± 0.5% of rate and ± 0.1% f.s. at calibration conditions, on request (max. 100 ln/min)
 ± 1% F.S. for MF53/63 above 1100 ln/min

Repeatability ± 0.25% of rate
Rangeability 50:1 (within specified accuracy)
Controllability 100:1 (i.e. total operating range)
Stability Less than ± 0.5% of rate per year
Temperature Effect Less than 0.015%/°C of rate shift from original calibration over 0-70°C

PHYSICAL SPECIFICATIONS

Materials of Construction Wetted parts stainless steel with Viton®, Buna-N®, PTFE/Kalrez® or EPDM seals.

Mechanical Connections NPT(F), Tube compression, VCR and VCO Option: Flanged DIN-or ANSI type available.*

Electrical Connections Terminal strip, accesible via PG 11 cable gland. Or fixed cable with flying leads. M20 for Profibus.

SPECIFICATIONS

Certification * CE certified.
EMC Directive (89/336/EEC)
EN 61326-1: 1997 + A1: 1998.
*  II 3 GD T 85 °C EEx nV II T4 KEMA 98ATEX4887
* Pressure Equipment Directive (97/23/EC).
See Installation and Instruction manual for more details.

Protection grade IP 65 and NEMA 4X.

Flow ranges and pressure ratings

Brooks Smart Mass Flow Products					
Mass Flow Controller	Mass Flow Meter	Flow Ranges N2-equivalent			Pressure Rating
Model	Model	Min. f.s.	Max. f.s.		Unit ¹
MF50S	MF60S ²	0.003	30	l _n /min	100 bar
MF51S	MF61S	20	100	l _n /min	100 bar
MF53S	MF63S	100	2500	l _n /min	70 bar
	MF64	18	2160	m ³ _n /h	Depending on Flowrange and connections ³

¹ Referring to normal conditions: I.e 0°C, 1013,25 mbar.

² MF60 can be used at 300 bar.

³ See IOM for details.

Setpoint Input Voltage:
0 - 5 Vdc or 1 - 5 Vdc input impedance > 2000 Ohm minimum
or Current :
0 - 20 mA or 4 - 20 mA 250 Ohm impedance

Analogue Output * Voltage : 0 - 5 Vdc or 1 - 5 Vdc 2000 Ohm
and : 0 - 20 mA or 4 - 20 mA Max loop resistance 375 Ohm
HART based programming codes for interface with PC)

Digital Communication* RS-232 or RS-485*
Baudrate 1200, 2400, 3600, 4800, 7200, 9600, 19k2, 38k4*
(Default: RS-232, Baudrate 9600)
Profibus-DP up to 12 Mbit/sec. (self switching)

Alarm If self-diagnostics detects a failure, the alarm mode will be activated. (TTL) Open Collector Output, signal grounded when activated. Max. 30 Vdc, 25 mA.
Or via communication port, when used digitally.

Power requirements +15Vdc to +28Vdc

Power Consumption Models MF60S, MF61S, MF63S and MF64S:
+ 24 Vdc (± 10%) @ 80 mA
Mass Flow Meters for + 15 Vdc (± 5%) @ 90 mA
Power Consumption Models MF50 S, MF51 S and MF53 S:
Mass Flow Controllers + 24 Vdc (± 10%) @ 140 mA for + 15 Vdc (± 10%) @ 185 mA

Note: With valve override function actuated the total power consumption specifications are: for +15 Vdc at 285 mA or for +24 Vdc at 370 mA
Temperature Both amb. and process gas: 0-70 °C.

Leak Integrity Outboard: 1 x 10⁻⁹ mbar l/sec. Helium.

Security To prevent "unauthorized" setting or reranging of span or zero, these functions are only accessible via the Brooks Smart Control, model 0160, or using Smart DDE, model 0162.

Warm up Time < 10 minutes; 1% F.S.

accuracy. Performance within specifications: 45 minutes.

Damping Damping from 0 to 10 seconds is possible for the flow output signal(s). *

Response Standard response of the flow output signal 1 sec. Response up to 0.2 sec. is on request.

Settling Time Standard 1 sec. Settling time up to 0.2 sec. is possible (to within 2% full scale of final value) for any command (setpoint) step; virtually without any dead time, over- or under shoot. Model MF53S 3 sec. (1 sec. on request).

* To be specified at ordering

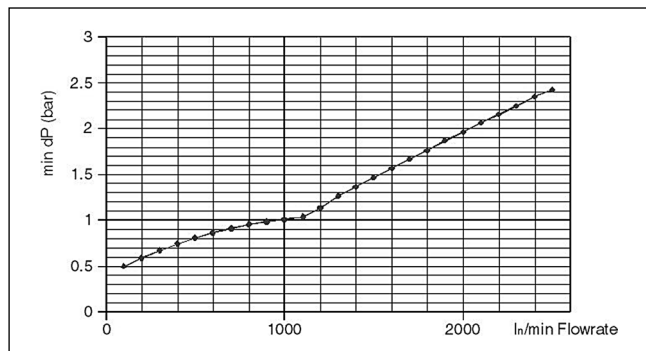

Figure 7: Min. Pressuredrop versus Flowrate for Model MF53 (1 bar = 14.5 psi)

DIMENSIONAL DRAWINGS

MF50 CONTROLLER

CONNECTION	"A" dim in	
	Inches	mm
9/16-18 UNF	5.28	134
1/4" NPT	6.87	174,5
1/4" BSP	6.87	174,5
1/8" Tb Cp.	7.13	181
6mm Tb Cp.	7.30	185,5
1/4" Tb Cp.	7.30	185,5
3/8" Tb Cp.	7.42	188,5
10mm Tb Cp.	7.42	188,5
1/2" Tb Cp.	7.58	192,5
1/4" VCR	7.17	182
1/2" VCR	7.46	189,5
1/4" VCO	6.85	174
1/2" VCO	7.28	185

MF60 METER

CONNECTION	"A" dim in	
	Inches	mm
9/16-18 UNF	3.89	98,7
1/4" NPT	5.47	139
1/4" BSP	5.47	139
1/8" Tb Cp.	5.73	145,5
6mm Tb Cp.	5.90	150
1/4" Tb Cp.	5.90	150
3/8" Tb Cp.	6.02	153
10mm Tb Cp.	6.02	153
1/2" Tb Cp.	6.18	157
1/4" VCR	5.77	146,5
1/2" VCR	6.06	154
1/4" VCO	5.45	138,5
1/2" VCO	5.89	149,5

MF51 CONTROLLER

CONNECTION	Without filter		With filter	
	Inches	mm	Inches	mm
9/16-18 UNF	5.85	148,5	7.26	184,5
1/4" NPT	7.44	189	8.86	225
1/4" BSP	7.44	189	8.86	225
1/8" Tb Cp.	7.70	195,5	9.11	231,5
6mm Tb Cp.	7.87	200	9.29	236
1/4" Tb Cp.	7.87	200	9.29	236
3/8" Tb Cp.	7.99	203	9.41	239
10mm Tb Cp.	7.99	203	9.41	239
1/2" Tb Cp.	8.15	207	9.57	243
1/4" VCR	7.74	196,5	9.15	232,5
1/2" VCR	8.03	204	9.45	240
1/4" VCO	7.42	188,5	8.84	224,5
1/2" VCO	7.85	199,5	9.27	235,5

MF61 METER

CONNECTION	Without filter		With filter	
	Inches	mm	Inches	mm
9/16-18 UNF	4.46	113,2	5.87	149,2
1/4" NPT	6.04	153,5	7.46	189,5
1/4" BSP	6.04	153,5	7.46	189,5
1/8" Tb Cp.	6.30	160	7.72	196
6mm Tb Cp.	6.48	164,5	7.89	200,5
1/4" Tb Cp.	6.48	164,5	7.89	200,5
3/8" Tb Cp.	6.59	167,5	8.01	203,5
10mm Tb Cp.	6.59	167,5	8.01	203,5
1/2" Tb Cp.	6.78	172	8.19	208
1/4" VCR	6.34	161	7.76	197
1/2" VCR	6.63	168,5	8.05	204,5
1/4" VCO	6.02	153	7.44	189
1/2" VCO	6.46	164	7.87	200

MF53 CONTROLLER

CONNECTION	"A" dim in	
	Inches	mm
9/16-18 UNF	9.27"	235,4
1-1/16-12 UN	9.27"	235,4
1/2" NPT	9.27"	235,4
1" NPT	9.27"	235,4
1,5" NPT	9.27"	235,4
1/2" BSP	9.27"	235,4
1" BSP	9.27"	235,4
1/2" Tb Cp.	11,95"	303,5
1" Tb Cp.	11,95"	303,5
3/4" Tb Cp.	12,28"	312
1" VCR	11,45"	291
3/4" VCR	12,48"	317
1/2" VCO	11,28"	286,5
3/4" VCO	11,54"	293
1" VCO	11,67"	296,5

MF63 METER

CONNECTION	"A" dim in	
	Inches	mm
9/16-18 UNF	7.54"	191,6
1-1/16-12 UN	7.54"	191,6
1/2" NPT	7.54"	191,6
1" NPT	7.54"	191,6
1,5" NPT	7.54"	191,6
1/2" BSP	7.54"	191,6
1" BSP	7.54"	191,6
1/2" Tb Cp.	10,24"	260
1" Tb Cp.	10,24"	260
3/4" Tb Cp.	10,57"	268,5
1/2" VCR	9,72"	247
3/4" VCR	10,75"	273
1/2" VCO	9,56"	242,5
3/4" VCO	9,82"	249,5
1" VCO	9,94"	252,5

DIMENSIONAL DRAWINGS

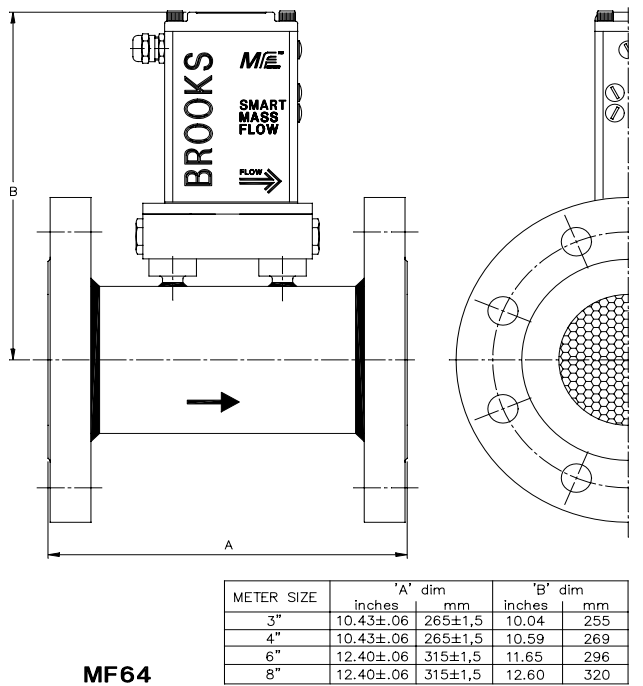
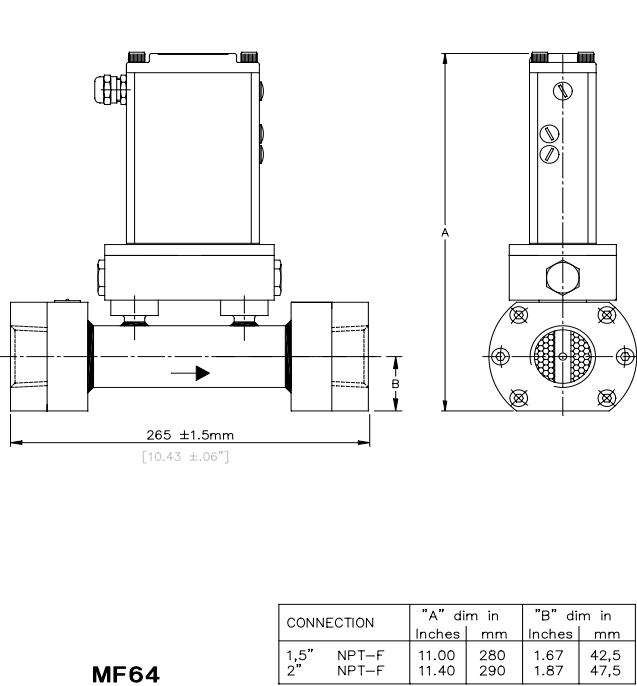
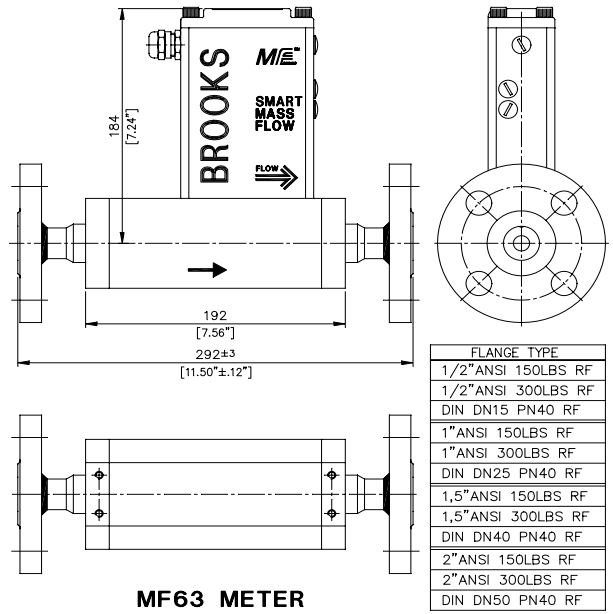
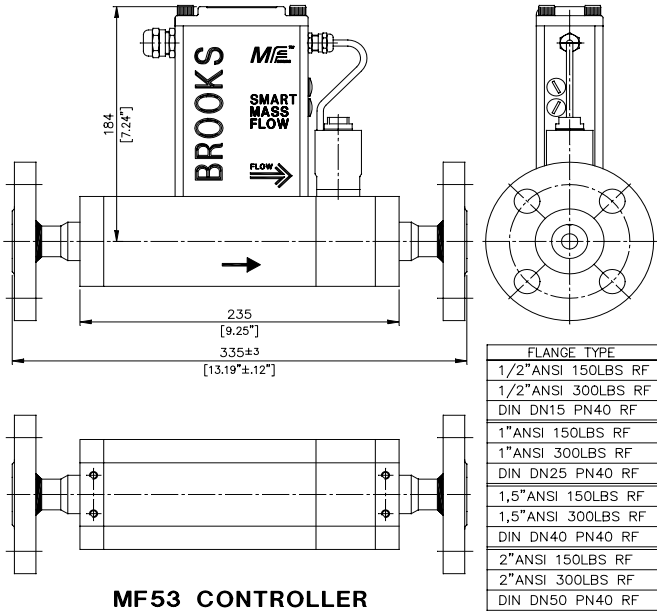

STANDARD EXECUTION

PROFIBUS CONNECTOR (RECOMMENDED)

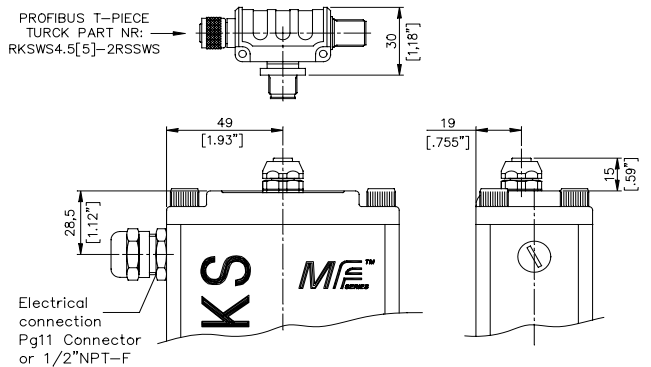
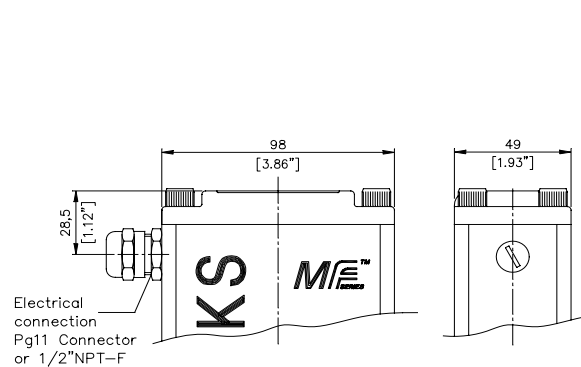

MODELLISTING

BROOKS MF-SERIES SMART MASS FLOW METERS / CONTROLLERS		
BASE MODEL NUMBER	DESCRIPTION	
MF60S/AA	MASS FLOW METER; F.S. FLOWRANGES: 0.003 - 0.008 l ⁿ /min.	
MF60S/AC	MASS FLOW METER; F.S. FLOWRANGES: 0.008 - 30 l ⁿ /min.	
MF61S/AD	MASS FLOW METER; F.S. FLOWRANGES: 20 - 100 l ⁿ /min.	
MF63S/AE	MASS FLOW METER; F.S. FLOWRANGES: 100 - 200 l ⁿ /min.	
MF63S/AF	MASS FLOW METER; F.S. FLOWRANGES: 200 - 300 l ⁿ /min.	
MF63S/AG	MASS FLOW METER; F.S. FLOWRANGES: 300 - 400 l ⁿ /min.	
MF63S/AH	MASS FLOW METER; F.S. FLOWRANGES: 400 - 500 l ⁿ /min.	
MF63S/AJ	MASS FLOW METER; F.S. FLOWRANGES: 500 - 600 l ⁿ /min.	
MF63S/AK	MASS FLOW METER; F.S. FLOWRANGES: 600 - 700 l ⁿ /min.	
MF63S/AL	MASS FLOW METER; F.S. FLOWRANGES: 700 - 800 l ⁿ /min.	
MF63S/AM	MASS FLOW METER; F.S. FLOWRANGES: 800 - 900 l ⁿ /min.	
MF63S/AN	MASS FLOW METER; F.S. FLOWRANGES: 900 - 1000 l ⁿ /min.	
MF63S/A1	MASS FLOW METER; F.S. FLOWRANGES: 1001 - 1100 l ⁿ /min.	
MF63S/A2	MASS FLOW METER; F.S. FLOWRANGES: 1101 - 1300 l ⁿ /min.	
MF63S/A3	MASS FLOW METER; F.S. FLOWRANGES: 1301 - 1600 l ⁿ /min.	
MF63S/A4	MASS FLOW METER; F.S. FLOWRANGES: 1601 - 1900 l ⁿ /min.	
MF63S/A5	MASS FLOW METER; F.S. FLOWRANGES: 1 901 - 2200 l ⁿ /min.	
MF63S/A6	MASS FLOW METER; F.S. FLOWRANGES: 2201 - 2500 l ⁿ /min.	
MF64S/AO	MASS FLOW METER; F.S. FLOWRANGES: 18 - 80 m ³ n/h. (1,5")	
MF64S/AP	MASS FLOW METER; F.S. FLOWRANGES: 60 - 140 m ³ n/h. (2")	
MF64S/AR	MASS FLOW METER; F.S. FLOWRANGES: 140 - 320 m ³ n/h. (3")	
MF64S/AS	MASS FLOW METER; F.S. FLOWRANGES: 240 - 540 m ³ n/h. (4")	
MF64S/AT	MASS FLOW METER; F.S. FLOWRANGES: 540 - 1250 m ³ n/h. (6") [2D]	
MF64S/AU	MASS FLOW METER; F.S. FLOWRANGES: 970 - 2160 m ³ n/h. (8") [2D]	
MF50S/AA	MASS FLOW CONTROLLER; F.S. FLOWRANGES: 0.003 - 0.008 l ⁿ /min.	
MF50S/AC	MASS FLOW CONTROLLER; F.S. FLOWRANGES: 0.008 - 30 l ⁿ /min.	
MF51S/AD	MASS FLOW CONTROLLER; F.S. FLOWRANGES: 20 - 100 l ⁿ /min.	
MF53S/AE	MASS FLOW CONTROLLER; F.S. FLOWRANGES: 100 - 200 l ⁿ /min.	
MF53S/AF	MASS FLOW CONTROLLER; F.S. FLOWRANGES: 200 - 300 l ⁿ /min.	
MF53S/AG	MASS FLOW CONTROLLER; F.S. FLOWRANGES: 300 - 400 l ⁿ /min.	
MF53S/AH	MASS FLOW CONTROLLER; F.S. FLOWRANGES: 400 - 500 l ⁿ /min.	
MF53S/AJ	MASS FLOW CONTROLLER; F.S. FLOWRANGES: 500 - 600 l ⁿ /min.	
MF53S/AK	MASS FLOW CONTROLLER; F.S. FLOWRANGES: 600 - 700 l ⁿ /min.	
MF53S/AL	MASS FLOW CONTROLLER; F.S. FLOWRANGES: 700 - 800 l ⁿ /min.	
MF53S/AM	MASS FLOW CONTROLLER; F.S. FLOWRANGES: 800 - 900 l ⁿ /min.	
MF53S/AN	MASS FLOW CONTROLLER; F.S. FLOWRANGES: 900 - 1000 l ⁿ /min.	
MF53S/A1	MASS FLOW CONTROLLER; F.S. FLOWRANGES: 1001 - 1100 l ⁿ /min.	
MF53S/A2	MASS FLOW CONTROLLER; F.S. FLOWRANGES: 1101 - 1300 l ⁿ /min.	
MF53S/A3	MASS FLOW CONTROLLER; F.S. FLOWRANGES: 1301 - 1600 l ⁿ /min.	
MF53S/A4	MASS FLOW CONTROLLER; F.S. FLOWRANGES: 1601 - 1900 l ⁿ /min.	
MF53S/A5	MASS FLOW CONTROLLER; F.S. FLOWRANGES: 1 901 - 2200 l ⁿ /min.	
MF53S/A6	MASS FLOW CONTROLLER; F.S. FLOWRANGES: 2201 - 2500 l ⁿ /min.	
MECHANICAL CONNECTIONS		
1A	WITHOUT ADAPTORS (9/16"-18" UNF) (ONLY FOR MF50/60/51/61/53/63)	
1B	1/4" TUBE COMPRESSION FITTINGS (ONLY FOR MF50/60/51/61)	
1C	1/8" TUBE COMPRESSION FITTINGS (ONLY FOR MF50/60/51/61)	
1D	3/8" TUBE COMPRESSION FITTINGS (ONLY FOR MF50/60/51/61)	
1E	1/4" VCR (ONLY FOR MF50/60/51/61)	
1F	1/4" VCO (ONLY FOR MF50/60/51/61)	
1G	1/4" NPT (ONLY FOR MF50/60/51/61)	
1H	6mm TUBE COMPRESSION FITTINGS (ONLY FOR MF50/60/51/61)	
1J	10mm TUBE COMPRESSION FITTINGS (ONLY FOR MF50/60/51/61)	
1K	1/4" BSP (F) (ONLY FOR MF50/60/51/61)	
1Y	1/2" BSP (F) (ONLY FOR MF53/63)	
1Z	1" BSP (F) (ONLY FOR MF53/63)	
2A	1 1/16" - 12SAE/MS (ONLY FOR MF53/63)	
2B	1/2" TUBE COMPRESSION FITTINGS (ONLY FOR MF50/60/51/61/53/63)	
2C	3/4" TUBE COMPRESSION FITTINGS (ONLY FOR MF53/63)	
2D	1" TUBE COMPRESSION FITTINGS (ONLY FOR MF53/63)	
2E	1/2" NPT(F) (ONLY FOR MF53/63)	
2F	1" NPT(F) (ONLY FOR MF53/63)	
2G	1 1/2" NPT(F) (SEE OPTION "B") (ONLY FOR MF53/63/64)	
2H	1/2" VCO (200 l ⁿ /min. max.) (ONLY FOR MF50/60/51/61/53/63)	
2J	3/4" VCO (ONLY FOR MF53/63)	
2K	1/2" VCR (200 l ⁿ /min. max.) (ONLY FOR MF50/60/51/61/53/63)	

BROOKS MF-SERIES	
SMART MASS FLOW METERS / CONTROLLERS	
BASE MODEL NUMBER	DESCRIPTION
MECHANICAL CONNECTIONS	
2L	DIN DN15PN40 (ONLY FOR MF53/63)
2M	DIN DN25PN40 (ONLY FOR MF53/63)
2N	DIN DN40PN40 (see option "B" for MF64) (ONLY FOR MF53/63/64)
2O	DIN DN50PN40 (see option "B" for MF64) (ONLY FOR MF53/63/64)
2P	ANSI ½" 150 LBS (ONLY FOR MF53/63)
2R	ANSI ½" 300 LBS (ONLY FOR MF53/63)
2S	ANSI 1" 150 LBS (ONLY FOR MF53/63)
2T	ANSI 1" 300 LBS (ONLY FOR MF53/63)
2U	ANSI 1½" 150 LBS (see option "B" for MF64) (ONLY FOR MF53/63/64)
2V	ANSI 1½" 300 LBS (ONLY FOR MF53/63)
2W	ANSI 2" 150 LBS (see option "B" for MF64) (ONLY FOR MF53/63/64)
2X	ANSI 2" 300 LBS (ONLY FOR MF53/63)
2Y	1" VCO (ONLY FOR MF53/63)
2Z	¾" VCR (ONLY FOR MF53/63)
3A	2"NPT (SEE OPTIONS B) (MF64 ONLY)
3B	ANSI 3" - 150 LBS (MF64 ONLY)
3C	ANSI 3" - 300 LBS (MF64 ONLY)
3D	ANSI 3" - 600 LBS [2D] (MF64 ONLY)
3E	DIN DN80 - PN40 [2D] (MF64 ONLY)
3F	DIN DN80 - PN64 [2D] (MF64 ONLY)
3G	DIN DN80 - PN100 [2D] (MF64 ONLY)
4A	ANSI 4" - 150 LBS (MF64 ONLY)
4B	ANSI 4" - 300 LBS (MF64 ONLY)
4C	ANSI 4" - 600 LBS [2D] (MF64 ONLY)
4D	DIN DN100 - PN16 [2D] (MF64 ONLY)
4E	DIN DN100 - PN40 [2D] (MF64 ONLY)
4F	DIN DN100 - PN64 [2D] (MF64 ONLY)
5A	6" ANSI - 150 LBS [2D] (MF64 ONLY)
5B	6" ANSI - 300 LBS [2D] (MF64 ONLY)
5C	6" ANSI - 600 LBS [2D] (MF64 ONLY)
5D	DIN DN 150 - PN 16 [2D] (MF64 ONLY)
5E	DIN DN 150 - PN 40 [2D] (MF64 ONLY)
5F	DIN DN 150 - PN 64 [2D] (MF64 ONLY)
6A	ANSI 8" - 150 LBS [2D] (MF64 ONLY)
6B	ANSI 8" - 300 LBS [2D] (MF64 ONLY)
6C	DIN DN200 - PN10 [2D] (MF64 ONLY)
6D	DIN DN200 - PN16 [2D] (MF64 ONLY)
6E	DIN DN200 - PN25 [2D] (MF64 ONLY)
6F	DIN DN200 - PN64 [2D] (MF64 ONLY)
9Z	SPECIFY
O-RING/VALVE SEAT MATERIAL	
A	VITON
B	BUNA (NOT FOR MF53)
C	PTFE/KALREZ (KALREZ FOR SENSOR O-RINGS AND VALVE SEAT) [2D]
D	KALREZ (NOT FOR MF53) [2D]
E	PTFE/EPDM (EPDM ONLY FOR VALVE SEAT) [2D]
F	PTFE [2D]
Z	SPECIFY
VALVE TYPE	
0	METER ONLY (NO VALVE)
1	NORMALLY CLOSED (MF50/51 SERIES)
2	NORMALLY CLOSED (PRESS.DIFF. >2BAR. MF53 SERIES)
3	NORMALLY CLOSED (PRESS.DIFF. <2BAR. MF53 SERIES)
4	NORMALLY OPENED (MF50 ONLY)
9	SPECIFY

**BROOKS MF-SERIES
SMART MASS FLOW METERS / CONTROLLERS**

BASE MODEL NUMBER		DESCRIPTION
ELECTRICAL INPUT/OUTPUT		
		INPUT OUTPUT
A		0-5Vdc 0-5 Vdc & 0-20mA (INCL. RS 232, 9600 BDS)
B		4-20mA 4-20 mA & 1-5Vdc (INCL. RS 232, 9600 BDS)
C		0-20 mA 0-20mA & 0-5Vdc (INCL. RS 232, 9600 BDS)
D		1-5Vdc 1-5 Vdc & 4-20mA (INCL. RS 232, 9600 BDS)
E		DIG. COMM. DIG. COMM. + 0 - 5 Vdc
F		DIG. COMM. DIG. COMM. + 4 - 20 mA
G		DIG. COMM. DIG. COMM. + 0 - 20 mA
H		DIG. COMM. DIG. COMM. + 1 - 5 Vdc
I		DIG. COMM. DIGITAL COMMUNICATION (ONLY)
Z		SPECIFY
COMMUNICATION / BAUDRATE		
A0		NONE (Communication will be possible via RS/232 and 9600 baud)
B*		RS232
C*		RS485
D0		PROFIBUS-DP (PNO CERTIFIED, 831-A-023 and 541-C-068-AAG)
*1		38400 Baud
*2		19200
*3		9600
*4		7200
*5		4800
*6		3600
*7		2400 * BOTH HAVE TO BE SPECIFIED
*8		1200
ELECTRICAL CONNECTION		
K		PG11 CABLE GLAND
L		1/2" NPT ADAPTER CONDUIT ENTRY
Z		SPECIFY
ENHANCEMENTS		
A		STANDARD RESPONSE:< 1 SEC (MF50/51) < 3 SEC (MF53) [1].
B		FAST RESPONSE (SPECIFY VALUES SEC.) [1]
C		LINEAR RAMP (SPECIFY VALUES%/SEC.) [1]
D		FLOW OUTPUT DAMPING (SPECIFY VALUES SEC.) [1]
ENHANCEMENTS		
0		UNCALIBRATED
1		STANDARD CALIBRATION INCLUDED (SEE OPTION C)
2		STORAGE OF MULTIPLE CAL. CURVES; ADD PER AVAILABLE CALIBRATION GAS
9		SPECIFY
POWER SUPPLY INPUT		
B		+ 24 Vdc = (Standard selection)
Z		SPECIFY
AREA CLASSIFICATION		
1		SAFE AREA [2D]
2		CERTIFIED FOR USE IN ZONE 2 According to ATEX [2D]
3		UL LISTED (NPT ENTRY) (ONLY MF64)
4		UL RECOGNIZED (PG11 ENTRY) (ONLY MF64)
5		WELDED SENSOR, NO CERT. (NPT ENTRY) (ONLY MF64) [2D]
6		WELDED SENSOR, NO CERT. (PG11 ENTRY) (ONLY MF64) [2D]
9		SPECIFY

MF50S / A C 1 H C 1 B A 0 K C 1 B 2 = TYPICAL MODEL NUMBER

NOTES:

1. ENHANCEMENTS

PLEASE FILL IN THE REQUESTED SPECIFICATIONS WHEN YOU HAVE DESCRIBED THE ENHANCEMENTS.
 Standard response time of the flow output signal: Model MF50/51 and MF60/60, standard 1 sec. or on request better than 0.2 sec. Model MF53/63, standard 3 sec. or on request better than 1 sec. Model MF64, 3 sec.
 Standard settling time for controllers: Model MF50/51, standard 1 sec. or on request better than 0.2 sec.
 Model MF53, standard 3 sec. or on request better than 1 sec. (to within 2%full scale of final value)

2. OPTIONS

- A) FOR GASES WHICH CLOG AND CONTAMINATE THE MFC EASILY, AN ANTI-CLOG LAMINAR FLOW ELEMENT MUST BE ORDERED. FOR FLOW RANGES UP TO 3460 mln/min. N2
- B) DIN/ANSI (PN40/150 LBS PRESSURE RATING) FLANGED CONNECTION FOR THE 1,5" AND 2" MF64S
- C) ENHANCED ACCURACY SPECIFICATIONS: 0.5% OF RATE PLUS 0.1% F.S. (Flow range 50 mln/min to 100 ln/min)
- D) NOT FOR UL LISTED OR RECOGNIZED MODELS.

Models MF50S-MF64S

BROOKS LOCAL AND WORLDWIDE SUPPORT

Brooks is committed to assuring all of our customers receive the ideal flow solution for their application, along with outstanding service and support to back it up. We operate first class repair facilities located around the world to provide rapid response and support. Each location utilizes primary standard calibration equipment to ensure accuracy and reliability for repairs and recalibration. The primary standard calibration equipment to calibrate our flow products is certified by our local Weights and Measures Authorities and traceable to the relevant International Standards.

Visit www.BrooksInstrument.com to locate the service location nearest to you.

START-UP SERVICE AND IN-SITU CALIBRATION

Brooks Instrument can provide start-up service prior to operation when required. For some process applications, where ISO-9001 Quality Certification is important, it is mandatory to verify and/or (re)calibrate the products periodically. In many cases this service can be provided under in-situ conditions, and the results will be traceable to the relevant international quality standards.

CUSTOMER SEMINARS AND TRAINING

Brooks Instrument can provide customer seminars and dedicated training to engineers, end users and maintenance persons. Please contact your nearest sales representative for more details.

HELP DESK

In case you need technical assistance:

Americas ☎ 1-888-554-FLOW
Europe ☎ +(31) 318 549 290 Within Netherlands ☎ 0318 549 290
Asia ☎ +011-81-3-5633-7100

Due to Brooks Instrument's commitment to continuous improvement of our products, all specifications are subject to change without notice.

TRADEMARKS

Brooks Brooks Instrument, LLC
BUNA DuPont Dow Elastomers
Inconel Inco Alloys International, Inc.
Kalrez DuPont Dow Elastomers
Teflon E.I. DuPont de Nemours & Co.
Viton DuPont Performance Elastomers



Brooks Instrument
407 West Vine Street
P.O. Box 903
Hatfield, PA 19440-0903 USA
T (215) 362-3700
F (215) 362-3745
E-Mail BrooksAm@BrooksInstrument.com
www.BrooksInstrument.com

Brooks Instrument
Neonstraat 3
6718 WX Ede, Netherlands
T 31-318-549-300
F 31-318-549-309
E-Mail BrooksEu@BrooksInstrument.com

Brooks Instrument
1-4-4 Kitasuna Koto-Ku
Tokyo, 136-0073 Japan
T 011-81-3-5633-7100
F 011-81-3-5633-7101
E-Mail BrooksAs@BrooksInstrument.com