

Solartron 7827 digital viscosity analyser

Data sheet
IP7827

- ▶ Auto-ranging
- ▶ Virtually no maintenance
- ▶ Line density
- ▶ Line temperature
- ▶ Dynamic and kinematic viscosity



The 7827 is a unique digital process analyser designed for analytical applications requiring continuous on-line liquid viscosity measurement in pipelines or tanks. The 7827 digital viscosity transducer is now available for top mounting in open or closed tanks as a long stem version with stem lengths of up to 4000mm (160").

In addition to viscosity, the sensor simultaneously measures the density and temperature of the fluid, allowing dynamic and kinematic viscosity to be accurately determined. Reference of viscosity and density temperature values can also be determined using methods developed for the oil industry and based on API and ASTM D341 standards.

The analyser comprises a vibrating sensor and drive electronics. It is easily installed in a by-pass, pipeline, open tank, pressurised vessel, or flow-through sample chamber. A choice of construction materials and connections allows the sensor to be used in a broad range of applications.

Each measurement range is independently calibrated to achieve maximum accuracy. For applications where the measurement extends over more than one calibrated range an auto ranging facility is provided.

The 7827 digital viscosity transducer is designed to operate in conjunction with the 795X series remote viscosity computer electronics, the 795X flow computers (refer to ISA109) and in meter correction applications with any suitably configured compatible flow computers.

For installation accessories refer to data sheet IP7004.

Principle of Operation

The sensor is a simple tuning fork maintained in vibration electronically. The density is a function of the resonant frequency, the viscosity is a function of the bandwidth.

7827 digitally measures the frequency at a point A (the lower -3db point) and then at point B (the upper -3db point) - see diagram. From these two measurements the 795x Series Signal Converter can calculate the bandwidth (B-A), resonant frequency $((A+B)/2)$ and hence the Quality Factor (Resonant Frequency/Bandwidth), to give digitally determined values of the density and viscosity for the fluid.

$$Q = \frac{\text{Resonant Frequency}}{\text{Bandwidth}}$$

$$Q \propto \frac{1}{\sqrt{\text{Viscosity}}}$$

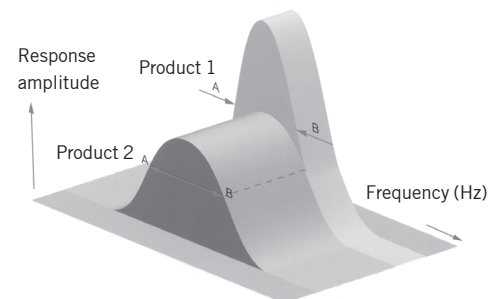

Product 1: Low viscosity
Product 2: High viscosity

Ordering information for standard forks

7827 Fork type digital viscosity transducer, frequency output (for use with viscosity or flow computers type 7950/1/5 or similar)													
Code		Materials of construction											
A	316 Stainless Steel	316 Stainless Steel tines	Standard finish										
C	316 Stainless Steel	316 Stainless Steel tines	Electro-polished										
F	316 stainless Steel	316 Stainless Steel tines	PTFE laminated tines										
V	304 stainless Steel	304 Stainless Steel tines	Standard finish										
E	Hastelloy C22	Hastelloy C22 tines	Standard finish										
D	Hastelloy C22	Hastelloy C22 tines	Electro-polished										
G	Hastelloy C22	Hastelloy C22 tines	PTFE laminated tines										
U	Hastelloy B2	Hastelloy B2 tines	Standard finish										
H	Monel 400	Monel 400 tines	Standard finish										
J	Monel 400	Monel 400 tines	Electro-polished tines										
L	Monel 400	Monel 400 tines	PTFE laminated tines										
T	Titanium	Titanium tines	Standard finish										
Z	Special: Use this letter code during quotation request												
Code		Amplifier system											
A	Frequency output ATEX II 2G EEx d IIC T4 (<200°C / 392°F)												
B	Frequency output CSA Class 1 Div 1 Groups C&D (<200°C / 392°F)												
Code		Amplifier housing											
A	Alloy (cast)												
Code		Process connections											
A	2" ANSI 150 RF												
B	2" ANSI 300 RF												
G	50 mm DIN 2527 RF DN 50/PN 40												
H	50 mm DIN 2527 RF DN 50/PN 100												
R	50 mm DIN 2527 RF DN 50/PN 16												
J	2" Ladish Triclamp (Hygienic)												
K	3" Ladish Triclamp (Hygienic)												
L	2" IDF (Hygienic)												
M	3" IDF (Hygienic)												
N	1.5" Cone seat compression fitting												
Z	Special: Use this letter code during quotation request												
Code		Stem length (nominal length)											
A	0 mm : no stem extension and with standard spigot												
Z	Special: Use this letter code during quotation request												
Code		Default configuration (Amplifier outputs)											
T	No configuration (configured in remote electronics)												
Z	Special: Use this letter for any special configuration												
Code		Calibration type											
B	0.5 to 100cP												
C	0.5-1000cP												
D	0.5-12,500cP												
E	10-12,500cP												
F	10-1000cP												
G	100-12,500cP												
Z	Special: Use this letter for any special configuration												
Code		Calibration boundary											
A	Free Stream												
B	2" Schedule 40 boundary												
C	3" Schedule 40 boundary												
D	2" Schedule 80 boundary												
E	3" Schedule 80 boundary												
F	2" Hygienic												
G	3" Hygienic												
Z	Special: Use this letter for any special configuration												
Code		Reserved											
B	Default												
Code		Traceability											
A	None												
X	Certificates of material traceability												
7827	A	A	A	A	A	T	B	A	B	A	Typical ordering information		
5	6	7	8	9	10	11	12	13	14				



Ordering information for long stem forks



7827	Fork type digital viscosity transducer, frequency output (for use with viscosity or flow computers type 7950/1/5 or similar)										
Code	Materials of construction										
A	316 Stainless Steel, 316 Stainless steel tines, standard finish										
C	316 Stainless Steel, 316 stainless steel tines, Electro-polished										
F	316 stainless steel, 316 stainless steel tines, PTFE laminated tines										
Z	Special: Use this letter code during quotation request										
Code	Amplifier system										
G	Safe area: Frequency (long stem, <200°C / 392°F)										
H	Frequency output ATEX II 1/2G EEx d IIC T4 (long stem, <150°C / 302°F)										
Z	Special: Use this letter code during quotation request.										
Code	Amplifier housing										
A	Alloy (cast)										
C	Stainless Steel										
Code	Process connections										
A	2" ANSI 150 RF										
B	2" ANSI 300 RF										
C	2" ANSI 600 RF										
G	50 mm DIN 2527 DN 50/PN 40										
H	50 mm DIN 2527 RF DN 50/PN 100										
R	50 mm DIN 2527 DN 50/PN 16										
T	No Connectors (open tank) - safe area only										
Z	Special: Use this letter code during quotation request										
Code	Stem length (nominal length)										
C	500 mm / 20" with removable transit cover										
D	750 mm / 30" with removable transit cover										
E	1000 mm / 40" with removable transit cover										
F	1500 mm / 60" with removable transit cover										
G	2000 mm / 80" with removable transit cover										
H	3000 mm / 120" with removable transit cover										
J	4000 mm / 160" with removable transit cover										
Z	Special: Use this letter code during quotation request										
Code	Default configuration (amplifier outputs)										
T	No configuration (configured in remote electronics)										
Code	Calibration type										
B	0.5 to 100cP										
C	0.5-1000cP										
D	0.5-12,500cP										
E	10-12,500cP										
F	10-1000cP										
G	100-12,500cP										
Z	Special: Use this letter for any special configuration										
Code	Calibration boundary										
A	Free Stream										
Z	Special: Use this letter for any special configuration										
Code	Reserved										
B	Default										
Code	Traceability										
A	None										
X	Certificates of material traceability										
7827	A	G	A	A	C	T	B	A	B	A	Typical ordering information
	5	6	7	8	9	10	11	12	13	14	

Specification

Viscosity range	1 to 20,000 cP
Viscosity accuracy	±1% FS calibrated in range (0.2 cP in 0.5-10 cP range)*
Factory calibrated ranges	0.5 to 10; 10 to 100; 100 to 1000; 1,000 to 12,500cP**
Viscosity repeatability	±0.5% reading
Density accuracy	±0.001 g/cc (20°C / -68°F, 1bar A, 1cP)
Density range	0 to 3 g/cc / 0 to 187.28 lb/ft ³
Calibrated range	0.6 to 1.6 g/cc / 38 to 100 lb/ft ³
Repeatability	±0.0001 g/cc/°C (corrected)
Temperature range	
Process	-50°C to +200°C / -60°F to +392°F
Ambient	-40°C to +85°C / -40°F to +185°F
Pressure range	207bar (max working)**** (3000psi)
Viscosity temperature effect	Negligible
Density temperature effect	±0.0001 g/cc/°C (corrected)
Material of wetted parts	316L St Steel, Hastelloy C22 or Monel 400
Flow velocity (maximum)	0.5 m/s (1.6 ft/s)
Power supply (from signal converter)	24 to 27 Vdc, 50mA
Output signals	Viscosity and density: frequency Temperature - 100Ω PRT 4 wire
Environmental rating	IP66
Weight (standard fork maximum)	6.7 kg (14.7lb)
Approvals ***	ATEX II 2G EEx d IIC T4
	CSA Class 1, Division 1, Group C & D
	EMC EN61326

- * Accuracy holds for Newtonian fluids only over the calibrated ranges
 ** Calibration for flow-through chambers not available above 1000cP
 *** NOTE: Where ATEX is required the process temperature is further limited for long stem variants to -40°C to +150°C / -4°F to + 302°F
 **** For long stem version pressure is limited to 100 bar (max working) (1450 psi)

Dimensions

Flange connection details

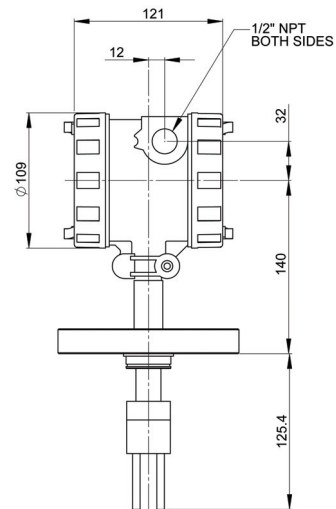

Solartron Mobrey Limited

158 Edinburgh Avenue Slough
 Berks UK SL1 4UE
 Tel: 01753 756600
 Fax: 01753 823589
 e-mail: sales@solartron.com
 www.solartronmobrey.com

Solartron Mobrey

19408 Park Row, Suite 320,
 Houston TX 77084 USA
 Tel: 281 398 7890
 Fax: 281 398 7891
 e-mail: sales@solartron.com
 www.solartronusa.com



Solartron Mobrey GmbH	Deutschland	tel: 0211/99 808-0
Solartron Mobrey Ltd	China	tel: 021 6353 5652
Solartron Mobrey sp z o o	Polska	tel: 022 871 7865
Solartron Mobrey AB	Sverige	tel: 08-725 01 00
Solartron Mobrey SA	France	tel: 01.30.17.40.80
Solartron Mobrey SA-NV	Belgium	tel: 02/465 3879



The right is reserved to amend details given in this publication without notice