



One Series Dual Output

One Series
Dual Output

ELECTRONIC PRESSURE, DIFFERENTIAL PRESSURE AND TEMPERATURE SWITCHES

PRODUCT FEATURES

- All Solid State Design
- Two Independent Set Points
- Patented I Am Working (IAW®) Self - Diagnostics
- Class I, Division 2 Approved
- Optional 4-20 mA analog output



UNITED ELECTRIC
CONTROLS

One Series Dual Output

One Series Dual Output

OVERVIEW

One Series Dual Electronic Pressure, Differential Pressure & Temperature Switches are designed for critical alarm and shutdown applications in harsh hazardous environments. A local indicator provides continuous notification that the device is powered, healthy and whether the switch has tripped. The patented I Am Working (IAW[®]) self diagnostics assure the operator that the One Series will perform when called upon.

Low level DC outputs (configurations D2A and D2B) may be used to trigger control circuits or as a discrete input to a process computer (DCS or PLC). Models configured with 115 VAC and 230 VAC input/output enable the One Series to be powered by an AC source and switch AC or DC loads.

The switch output modes may be configured by the user in the field without re-wiring. An optional 4 to 20 mA analog output allows remote monitoring and trending of the process variable.

The self-contained, compact package allows for easy retrofit of mechanical switches or transmitters.

Approved for Division 2 hazardous locations and harsh environmental conditions, this rugged design will stand up to your most demanding applications.

FEATURES

- 18-30 VDC, 115 VAC or 230 VAC power supply
- Real time local digital display of process variable
- Optional 4 to 20 mA analog output
- Adjust and setup in place
- Set point and deadband for both outputs are independantly adjustable over the entire range
- Solid-state switching provides extended switch life with no contact wear; no moving parts
- Approved for Division 2 locations; Enclosure Type 4X
- 3 year warranty



TRADITIONAL SWITCH FEATURES:

- AC or DC operation
- Low cost
- Simple to wire and operate
- Dual, independently-set outputs

TRANSMITTER FEATURES:

- Solid-state performance. No moving parts
- Live zero, "health indication"
- Remote indication of process variable

THE ONE SERIES COMBINES THE BEST FROM EACH, AND MORE!

- AC or DC operation
- Dual solid-state outputs. No moving parts. Reliable operation

- Communicates "I Am Working" and "I Have Switched" status. IAW® patent number U.S. 6,339,373
- Local display of process variable
- Local setting of set points, deadbands and switch modes. Deadbands adjustable between 0 and 100% of range!
- Non-volatile storage (and display) of minimum and maximum process extremes
- Combines a gauge, a transmitter and a dual output switch all in one package; using one process connection
- Optional 4-20 mA trending output
- Economical; about half the cost of a process transmitter

APPLICATIONS

The One Series combines the best features of traditional switches and transmitters in one package. Use it for all threshold detection and switching applications.

The One Series Dual can be used in applications where alarm/shutdown or high alarm/low alarm are desired from one process connection

Rugged construction, wide media compatibility and flexible mounting options combine to make the One Series the ideal choice for monitoring and controlling critical pressure and temperature thresholds for a variety of process applications. It can also help you satisfy standards such as ISA S84.01 and IEC 61508 in areas such as redundancy, diverse technologies and reduced testing intervals. The One Series employs solid-state technology with no moving parts and is approved for use in Class I, Division 2 hazardous locations by UL for USA and Canadian installations.

Pipelines & Pumping Stations



Chemical Plants and Refineries



One Series Dual Output

One Series Dual Output

One Series Dual: 24 VDC Models (D2A & D2B)*

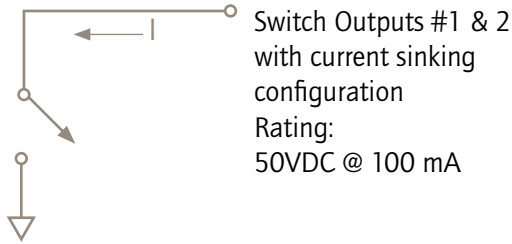

One Series Dual: 24 VDC Models (D2A, D2B with M031 option)*

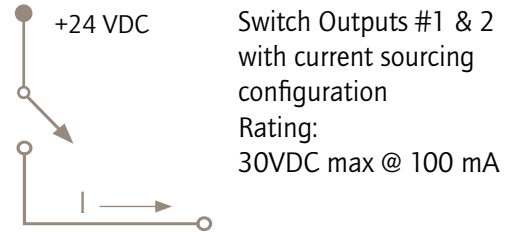

One Series Dual: 115 & 230 VAC Models (D2D, D2E with option M034 or M035)*

Switch Output #1

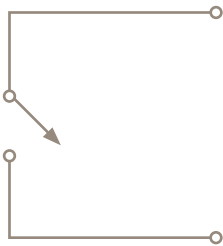

Switch Outputs #1 & 2 with free contacts
Ratings:
M034 - 50 VDC/VAC @ 100 mA
M035 - 280 VAC @ 1A

Switch Output #2

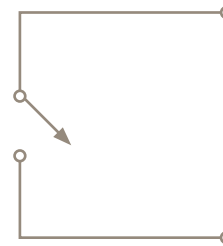

TECHNOLOGY

UNIQUE IAW[®] FUNCTION, patent number 6,339,373

The One Series Dual provides a local continuous indication of its health and the switch output status. An LED on the front panel is used to communicate three states:

- I Am Working but I Have Not Switched
- I Am Working and I Have Switched
- I Am Not Working

The One Series IAW[®] feature continuously monitors the health of the sensor, software, microprocessor and power supply. Functions of the IAW[®] signal are as follows:

IAW [®] Signal	Interpretation
IAW [®] output "On" continuously	Normal operation, unit operating properly
IAW [®] output flashing	Beyond set point, unit operating properly
IAW [®] output "Off"	Loss of power or unit inoperable

* See Configuration Selection Guide (pg 17-18) for other input/output options

100% SET POINT AND DEADBAND ADJUSTMENT

Set point and deadband values for both outputs are adjustable over the full range span using a convenient, simple to operate, front panel keypad. Access to the programming mode requires a simple, yet tamper resistant keying sequence... It's better than password protection!

The easy-to-use local programmability of the One Series provides the following benefits:

- Eliminates sacrificing wide range adjustability to achieve a specific deadband
- Deadband adjustability from 0-100% of range provides ideal pump operation.
- No more guessing about the set point or deadband values or the effects of hysteresis on the switch. All values may be displayed locally with the touch of a single button and then precisely adjusted to any point in the operating range
- High resolution for both the set point and the deadband values. See DISPLAY RESOLUTION TABLE on pg. 11

PROCESS VARIABLE EXTREMES STORED IN NON-VOLATILE MEMORY

System pressure or temperature extremes are retained in the One Series' non-volatile memory, assisting in troubleshooting system problems. The One Series continuously captures high and low pressure or temperature extremes values, providing a readout and a tamper-resistant key sequence for resetting.

- Captures and stores extreme swings (peaks and valleys) of the process variable
- Use the - extreme as a "leak down" tester
- Use the + extreme to evaluate relief valve and rupture disc performance
- Local display of +/- extreme values, with the push of a single button

CHOICE OF SWITCH OPERATING MODE

The One Series provides four convenient switch operating modes which determine the function of the switch output, deadband, IAW[®] LED status indicator signal, and LCD display messages. The local IAW[®] signal will flash when either switch of the unit is in a tripped condition. The desired switch operating mode can be selected from one of four options:

- High Limit Alarm - Close on Rise (NO)
- High Limit Shutdown - Open on Rise (NC)
- Low Limit Alarm - Close on Fall (NO)
- Low Limit Shutdown - Open on Fall (NC)

The switch operating mode provides the following benefits:

- Wire the unit, then select your desired switch output (NO or NC) from a menu on the One Series' display
- Select the operation of the switch, setpoint, and deadband with a few simple keystrokes
- Eliminate wiring hassles with a few keystrokes; reconfigure rather than rewire the product if the application or requirements change

One Series Dual Output

One Series Dual Output

EXCELLENT MEDIA COMPATIBILITY

Gauge pressure: Wetted materials include a 316 stainless steel pressure connection, ceramic pressure sensor and your choice of O-Ring material. The piezoresistive ceramic sensor is compatible with most media except a few aggressive acids.

Sanitary pressure: 316L stainless steel sanitary process fitting

Stainless-steel differential pressure: 316 welded sensor compatible with most media

Differential pressure (dry only): compatible with dry air and inert gases

Temperature: 304 stainless steel sensor sheath

OUTSTANDING REPEATABILITY

A 10 bit analog-to-digital converter and software calibration provide a highly accurate and stable reading of the process variable. Calibration constants are stored in non-volatile memory to ensure set point repeatability and eliminate the need to recalibrate the instrument.

- Switch repeatability: $\pm 0.2\%$ of full scale
- Display and 4-20mA accuracy: $\pm 1.0\%$ of full scale

FIELD TEST AND SET

After removing the protective LEXAN[®] cover, the user may easily vary the set point and/or deadband values to verify proper switch operation and check process extremes. Switch modes can be changed to produce Normally Open to Normally Closed functionality without wiring changes.

SPECIFICATIONS

(ALL SPECIFICATIONS AT 25°C (77° F) UNLESS OTHERWISE SPECIFIED)

SENSORS	
GAUGE PRESSURE	(Type 1) Ranges: 0 to 4000 psi (See MODEL CHART). Process connection: 1/2" NPT female, 316 stainless steel. Sensor: Ceramic (96% Alumina). O-Ring: Viton [®] is standard. (See HOW TO ORDER for other O-Ring materials)
SANITARY PRESSURE	(Type 5) Ranges: 0-600 psi (See MODEL CHART). Process connection: Tri-Clamp [®] compatible 1-1/2" or 2" 316L stainless steel with 3-A rated finish
STAINLESS DIFFERENTIAL PRESSURE	(Type 4) Ranges: 0-3000 psid (See MODEL CHART). Process Connection: 1/4" NPT female, 316L stainless steel welded diaphragms
DRY DIFFERENTIAL PRESSURE	(Type 3) Ranges: 0-5" wcd to 0-35 psid (see MODEL CHART). Process connection: 1/4" NPT female ports, compatible with dry air and inert gases (Silicon sensor with aluminum/plastic/glass/RTV wetted parts)

TEMPERATURE	(Type 2) Ranges: -50 to 1000°F (-46 to 538 °C) (See MODEL CHART). Model H: MI extension wire, 0.125" OD x 6', 10' or 20' long. Model R: Teflon [®] jacketed cable with Teflon [®] coated leads and stainless steel overbraid, 6', 10' or 20' long. Model L: 0.250" OD x 4", 6", 10"
MECHANICAL	
ENCLOSURE SPECIFICATIONS	Die-cast aluminum epoxy powder coated with removable Lexan [®] Cover ; Enclosure Type 4X (except "R" temperature models. "R" models are weather tight but do not carry a specific Enclosure Type 4X rating).
WEIGHT	Single enclosure units: 1-3/4 lbs. (0,8 kg); dual enclosure units: 2-1/2 lbs. (1,1 kg)
SHOCK	MIL-STD Method 516.4; 10 mSec @ 15 g's, 6 mSec @ 40 g's; 3 times each axis
VIBRATION	MIL-STD Method 514.4; 10-2000 Hz @ 0.04 PSD (equates to 8 g's @ 2000 Hz)
ELECTRICAL	
CONDUIT/ELECTRICAL CONNECTIONS	Single enclosure (switch rating A): 1/2" NPT female, sealed conduit with 1 meter wire harness, 20 AWG, PVC jacketed, shielded cable. See optional lengths (L100 and L200) Dual enclosure (switch rating B): 1/2" NPT female conduit connection; terminal block, accommodates 20 to 14 AWG conductors Dual enclosure (switch rating D and E): dual 1/2" NPT female conduit connections; separate terminal blocks for high and low voltage signals, accommodates 22 to 14 AWG conductors
POWER SOURCE	Switch rating A & B : 24 VDC nominal, 18 to 30 VDC; 100 mA maximum (surge protected). Switch rating D: 115 VAC nominal, +/- 10%. Switch rating E: 230 VAC nominal, +/- 10%
SWITCHED OUTPUTS (2)	Switch A & B: 24 VDC power supply, two SPST 50 VDC @ 100 mA open drain (collector) current sinking MOSFETs (see Option M031 & M032 for sourcing or free contact outputs) Switch rating D: 115 VAC power supply, two SPST 280 VAC @ 1A solid-state relays with free contacts (see Option M035) Switch rating D: 115 VAC power supply, two SPST 50 VDC/VAC @ 100 mA PhotoMOSFETs with free contacts (see Option M034) Switch rating E: 230 VAC power supply, two SPST 280 VAC @ 1 A solid-state relays with free contacts (see Option M035) Switch rating E: 230 VAC Power supply, two SPST 50 VDC/VAC @ 100 mA PhotoMOSFETs with free contacts (see Option M034)
OFF-STATE LEAKAGE CURRENT	Switch Rating A and B: 10 µA @ 50 VDC, power off fail-safe "open" Switch Rating D and E: Option M034 = 1 µA, Option M035 = 0.1 mA, power off fail-safe "open"
OPTIONAL ANALOG OUTPUT	4 to 20 mA sourcing output, non-isolated, proportional to sensor input range, load resistance 500Ω maximum (factory scalable with option M205)
EMI/RFI	Complies with CE EMC requirements EN50081-1, EN50082-2 (switch rating B only)
EMISSION	Conducted emission EN55011 class A; Radiated emission EN55011 class A
IMMUNITY	Electrostatic discharge EN61000-4-2; Conducted disturbances (RF) acc. IEC 1000-4-6; Radiated E-fields (RF) acc IEC 1000-4-3, acc ENV50204; Surge withstanding IEC 1000-5; Transient withstanding EN 61000-4-4
OPERATING	
RANGES	See MODEL CHART for pressure, differential pressure and temperature ranges
SET POINTS	Adjustable over the full range span. See MODEL CHART

One Series Dual Output

One Series Dual Output

DEADBANDS	Adjustable over the full range span. See MODEL CHART
MAXIMUM OVER RANGE	2X range. N/A for temperature ranges. See MODEL CHART
BURST PRESSURE	4X range. N/A for temperature ranges
SET POINT REPEATABILITY	±0.2% of maximum range value
ACCURACY	Switch point/indication: ±1.0% of maximum range value. Analog output: ±1.0% of maximum range value
MEDIA TEMPERATURE EFFECTS	±1.0% of maximum range from 32 to 158°F (0 to 70°C)
LONG-TERM STABILITY	±0.25% of range per year, maximum
SWITCH RESPONSE TIME	25 mSec typically, 200 mSec maximum

GENERAL FEATURES

AMBIENT TEMPERATURE	Operating: -22 to 158°F (-30 to 70°C) Storage: -22 to 176°F (-30 to 80°C) Dry Differential Pressure Model only: -22 to 122°F (-30 to 50°C)
MEDIA TEMPERATURE FOR GAUGE PRESSURE MODELS	Sensor type 1: Limited by O-ring material. See HOW TO ORDER Sensor type 5: 0 to 266°F (-17 to 130°C)
MEDIA TEMPERATURE FOR DIFFERENTIAL PRESSURE MODELS (SENSOR 3)	-20 to 150°F (-28 to 65°C) @ 65 psi -20 to 140°F (-28 to 60°C) @ 80 psi -20 to 120°F (-28 to 48°C) @ 120 psi
STAINLESS DIFFERENTIAL PRESSURE MODELS (SENSOR 4)	0 to 257°F (-17 to 125°C)
MEDIA TEMPERATURE FOR TEMPERATURE MODELS	-94 to 550°F (-70 to 288°C) (Models L & R) -94 to 1150°F (-70 to 621°C) (Model H)
LOCAL DIGITAL DISPLAY	2 Row by 16 character LCD display for indication of programming parameters and process variable; also displays extreme (min/max) pressure or temperature values
LOCAL IAW® STATUS LED	Local IAW® LED to indicate switch state and health status. Patent number 6,339,373
FIELD ACCESSIBLE PROGRAMMING	Convenient keypad allows for easy product configuration and adjustment
MEMORY	All programmed data stored in non-volatile memory (saved if power lost)
SWITCH OPERATING MODES	Field programmable for open or close on rising or falling condition

APPROVALS



UL Listed, **cUL** Certified
Class I, Division 2, Groups A, B, C, D, (Non-incendive)
Class II, Division 2, Groups F, G, (Non-incendive)
Class III; Enclosure type 4X (except "R" temperature models)
Class I, Zone 2, Group IIC T4



CE EMC Directive (standard on switch rating B. N/A on switch ratings A, D and E)
CE Compliance to Pressure Equipment Directive (PED 97/23EC)

Teflon® and **Viton®** are registered trademarks of E.I. DuPont Company
Lexan® is a registered trademark of General Electric Company
Afflas® is a registered trademark of Asahi Glass Co., Ltd.
Kalrez® is a registered trademark of E.I. DuPont Company
Tri Clamp® is a registered trademark of the TriClover Company
Lexan® is a registered trademark of the GE Plastics Company

MODEL CHART

Gauge Pressure

Sensor Type 1, 1/2" NPT female, 316 stainless steel pressure connection, piezoresistive ceramic pressure sensor, Viton O-ring (Other O-rings available. See HOW TO ORDER)

Model	Pressure Range		Maximum Over Range*	
	psi	bar	psi	bar
A	0 to 25	0 to 1,7	50	3,4
B	0 to 50	0 to 3,4	100	6,9
C	0 to 125	0 to 8,6	250	17,2
D	0 to 250	0 to 17,2	500	34,5
E	0 to 700	0 to 48,3	1400	96,5
F	0 to 1400	0 to 96,5	2800	193,1
G	0 to 2800	0 to 193,1	5600	386,1
H	0 to 4000	0 to 275,8	8000	551,6

Sanitary Pressure

Sensor Type 5, 316L stainless steel diaphragm, welded sensor; Tri-clamp® compatible pressure connection, 3A Rated Finish, NeoBee M-20 Oil Fill

Part Number	Pressure Range		Maximum Over Range*		Sensor Diameter
	psi	bar	psi	bar	
T1	0 to 25	0 to 1,7	50	3,4	1½"
T2	0 to 50	0 to 3,4	100	6,9	1½"
T3	0 to 125	0 to 8,6	250	17,2	1½"
T4	0 to 250	0 to 17,2	500	34,5	1½"
T5	0 to 600	0 to 41,4	1400	96,5	1½"
T6	0 to 25	0 to 1,7	50	3,4	2"
T7	0 to 50	0 to 3,4	100	6,9	2"
T8	0 to 125	0 to 8,6	250	17,2	2"
T9	0 to 250	0 to 17,2	500	34,5	2"

*The maximum pressure that may be applied continuously without causing damage and maintaining set point repeatability.

One Series Dual Output

One Series
Dual Output

Differential Pressure (dry air, inert gas)

Sensor Type 3, 1/4" NPT female pressure connections, silicon sensor, with aluminum/plastic/glass/RTV wetted parts. Suitable for sensing of dry air and inert gases. Optional plastic barb fittings available (Kit 62169-19)

Model	Differential Pressure Range (1)		Differential Over Range Pressure (2)		Working Pressure (3)	
	psid/(“wcd)	bar/(mbar)	psid	bar	psig	bar
K1	(0 to 5)	(0 to 12,4)	1	0,1	6	0,4
K2	(0 to 25)	(0 to 62,2)	20	1,4	100	6,9
K3	(0 to 80)	(0 to 199)	20	1,4	100	6,9
K4	0 to 5	(0 to 344,7)	30	2,1	100	6,9
K5	0 to 12	(0 to 827,4)	60	4,1	100	6,9
K6	0 to 35	0 to 2,4	100	6,9	100	6,9

Differential Pressure (Stainless, suitable for wet media)

Sensor Type 4, 316 welded stainless steel diaphragms with 1/4" NPT female pressure connections

Model	Differential Pressure Range (1)		Differential Over Range Pressure (2)		Working Pressure (3)	
	psid	bar	psid	bar	psi	bar
W4	0 to 100	6,9	300	20,7	1800	124,1
W5	0 to 300	20,7	900	62,1	2750	189,6
W6	0 to 1000	68,9	2000	137,9	2750	189,6
W7	0 to 3000	206,8	3000	206,8	3250	224,1

(1) Range is defined as the range of differential pressure between process inputs for which the sensor will operate within specified functional tolerances

(2) Differential Over Range Pressure is defined as the maximum difference in pressure between the process inputs. Exceeding this pressure differential at any working pressure may permanently damage the sensor performance

(3) Working Pressure is defined as the maximum pressure at either process input. Exceeding this pressure at either process input individually or simultaneously may permanently damage the sensor performance

Temperature

Sensor Type 2, 0.25" OD sensor housing, 304 stainless steel, 100 ohm RTD temperature sensor. NOTE: Must order PF73 compression fitting or SA6213-348 union connection if threaded connection is required. Accessory thermowells are also available

Model	Temperature Range	Maximum Over Range	Description
		The value at which the sensor may experience irreversible damage	
L1	-50 to 450°F (-45.6 to 232.2°C)	550°F (288°C)	Local sensor, 4" long
L2	-50 to 450°F (-45.6 to 232.2°C)	550°F (288°C)	Local sensor, 6" long
L3	-50 to 450°F (-45.6 to 232.2°C)	550°F (288°C)	Local sensor, 10" long
R1	-50 to 450°F (-45.6 to 232.2°C)	550°F (288°C)	Remote sensor, 6" long with 6' Teflon® extension wire
R2	-50 to 450°F (-45.6 to 232.2°C)	550°F (288°C)	Remote sensor, 6" long with 10' Teflon® extension wire
R3	-50 to 450°F (-45.6 to 232.2°C)	550°F (288°C)	Remote sensor, 6" long with 20' Teflon® extension wire
H1	-50 to 1000°F (-45.6 to 537.6°C)	1150°F (621°C)	Remote sensor, high temp., 2.5" long with 6' MI ext. wire
H2	-50 to 1000°F (-45.6 to 537.6°C)	1150°F (621°C)	Remote sensor, high temp., 2.5" long with 10' MI ext. wire
H3	-50 to 1000°F (-45.6 to 537.6°C)	1150°F (621°C)	Remote sensor, high temp., 2.5" long with 20' MI ext. wire
H4	-50 to 450°F (-45.6 to 232.2°C)	1150°F (621°C)	Remote sensor, 2.5" long with 6' MI ext. wire
H5	-50 to 450°F (-45.6 to 232.2°C)	1150°F (621°C)	Remote sensor, 2.5" long with 10' MI ext. wire
H6	-50 to 450°F (-45.6 to 232.2°C)	1150°F (621°C)	Remote sensor, 2.5" long with 20' MI ext. wire

DISPLAY RESOLUTION

The resolution of the display is dependent on the pressure range and display units. The values below represent the number of digits to the right of the decimal point. Display resolution for temperature ranges is 0.

Sensor	Model	Range	Number of Decimal Places				
			psi	bar	kPa	MPa	kg/cm ²
1	A	0-25 psi	2	2	1	n/a	2
1	B	0-50 psi	1	2	1	n/a	2
1	C	0-125 psi	1	2	0	n/a	2
1	D	0-250 psi	0	1	0	n/a	1
1	E	0-700 psi	0	1	0	n/a	1
1	F	0-1400 psi	0	1	0	n/a	1
1	G	0-2800 psi	0	0	n/a	2	0
1	H	0-4000 psi	0	0	n/a	2	0
3	K1	0-5" wcd	2	2 (mbar)	2	n/a	n/a
3	K2	0-25" wcd	1	1 (mbar)	2	n/a	n/a
3	K3	0-80 wcd	1	1 (mbar)	2	n/a	n/a
3	K4	0-5 psid	2	0 (mbar)	2	n/a	n/a
3	K5	0-12 psid	2	0 (mbar)	1	n/a	n/a
3	K6	0-35 psid	1	0 (mbar)	0	n/a	n/a
4	W4	0-100 psid	1	2	0	n/a	2
4	W5	0-300 psid	0	1	0	n/a	1
4	W6	0-1000 psid	0	1	0	n/a	1
4	W7	0-3000 psid	0	0	n/a	2	0
5	T1/T6	0-25 psi	2	2	1	n/a	2
5	T2/T7	0-50 psi	1	2	1	n/a	2
5	T3/T8	0-125 psi	1	2	0	n/a	2
5	T4/T9	0-250 psi	0	1	0	n/a	1
5	T5	0-600 psi	0	1	0	n/a	1

One Series Dual Output

HOW TO ORDER

Build a part number by selecting appropriate code for each feature category. Example: **D2A1B2N-M446**

D	2	A	1	B	2	N	-	M446
Setting/ Indicating Method	Switch Designation	Switch Rating/ Termination/ Power Supply	Sensor Type	Model	*O-Ring Material	Auxiliary Output		Miscellaneous Options

*Applicable only for pressure sensor type 1

ORDERING CODE	DESCRIPTION	D	2	A	1	B	2	N	-	M446
SETTING/INDICATION METHOD										(see next page)
D	User adjustable, digital indicating configuration									
SWITCH DESIGNATION										
2	Designation for One Series Dual product line with two switch outputs									
SWITCH RATING/TERMINATION/POWER SUPPLY (ALSO SEE LIST OF OPTIONS)										
A	Two MOSFET Open drain (collector) outputs with flying lead-wires									
B	Two MOSFET Open drain (collector) outputs with terminal block (upper enclosure included)									
D	Two 1 A 280 VAC solid-state relays with 115 VAC power supply and terminal blocks, upper enclosure and dual conduit ports (M035)									
D	Two 100 mA 50 VAC/VDC PhotoMOSFETs with 115 VAC power supply and terminal blocks, upper enclosure and dual conduit ports (M034)									
E	Two 1 A 280 VAC solid-state relays with 230 VAC power supply and terminal blocks, upper enclosure and dual conduit ports (M035)									
E	Two 100 mA 50 VAC/VDC PhotoMOSFETs with 230 VAC power supply and terminal blocks, upper enclosure and dual conduit ports (M034)									
SENSOR TYPE										
1	Gauge pressure, 316 stainless steel 1/2" NPT female pressure connection, ceramic sensor									
2	Temperature sensor									
3	Differential pressure (dry air), silicon sensor, 1/4" NPT female pressure connections, 180° opposite									
4	Differential pressure, 316 welded stainless steel diaphragms with 1/4" NPT female pressure connections									
5	Sanitary pressure, 316L stainless steel, 1 1/2" or 2" Tri-Clamp® connection									
MODEL RANGE										
A-H	Pressure, gauge									
T1-T9	Pressure, sanitary									
K1-K6	Differential pressure, dry									
W4-W7	Differential pressure, stainless									
L1-L3	Temperature, local									
R1-R3	Temperature, remote/teflon									
H1-H6	Temperature, remote/MI									
O-RING MATERIAL (SENSOR TYPE 1 ONLY)										
0	Viton®; media temperature 0 to 257°F (-17.8 to 125°C)									
1	Aflas®; media temperature 32 to 200°F (0 to 93.3°C)									
2	Buna N; media temperature -22 to 257°F (-30 to 125°C)									
3	EPR; media temperature -22 to 257°F (-30 to 125°C)									
4	Kalrez®; media temperature 32 to 257°F (0 to 125°C)									
AUXILIARY OUTPUT										
N	None									
A	4 to 20 mA analog process trending signal (sourcing output)									

HOW TO ORDER

Build a part number by selecting appropriate code for each feature category. Example: **D2A1B2N-M446**

D	2	A	1	B	2	N	-	M446
Setting/ Indicating Method	Switch Designation	Switch Rating/ Termination/ Power Supply	Sensor Type	Model	*O-Ring Material	Auxiliary Output		Miscellaneous Options

*Applicable only for pressure sensor type 1

D 2 A 1 B 2 N - M446

MISCELLANEOUS OPTIONS

M031	SW1 & SW2 are low-level VDC current sourcing (100 mA) outputs. One leg of each switch is tied to the device power supply. Available on D2A and D2B models only
M032	SW1: Free contact output for low-level 100 mA 50VDC/VAC. SW2: Low-level VDC current sourcing (100 mA) output. Available on D2A and D2B models only. 4-20 mA output is not available with this option
M034	Two PhotoMOS relay optically-isolated outputs with free contacts rated at 50 VDC/VAC @ 100 mA. IAW output N/A (available on D2D and D2E only)
M035	Two solid-state relays with free contacts rated at 280 VAC @ 1 A. IAW output N/A (available on D2D and D2E only)
M040	Sanitary Sensor with electropolish finish (Sensors type 5 only)
M041	Secondary barrier for hazardous media (sensors types 1, 4 and 5 only)
M202	Factory set parameters (set point, deadband and switch operating mode)
M205	Scale 4 to 20 mA output (Factory configured. Customer must specify upper and lower range limits)
M270	Display and nameplate units of measure in degrees C (temperature units only)
M276	Display and nameplate units of measure in mbar or bar (pressure units only. See "DISPLAY RESOLUTION" for availability)
M277	Display and nameplate units of measure in kPa or mPa (pressure units only. See "DISPLAY RESOLUTION" for availability)
M278	Display and nameplate units of measure in kg/cm ² (pressure units only. See "DISPLAY RESOLUTION" for availability)
M440	Cover chain
M444	Paper tag
M446	Stainless steel tag
M550	Oxygen service cleaning; (includes Viton [®] O-ring, sensors types 1, 4 and 5 only)
L100	10 feet long cable assembly (switch rating "A" only)
L200	20 feet long cable assembly (switch rating "A" only)
62169-19	3/16" plastic barb fitting kit (sensor type 3 only)
PF73	1/2" NPT compression fitting kit (temperature models R and L2, L3 only)
SA6213-348	1/2" union connector kit (temperature models R1-R3 and H1-H6 only)
62169-27	Lexan [®] replacement cover kit



One Series Dual Output

One Series Dual Output

DIMENSIONAL DRAWINGS

D2A CONFIGURATION

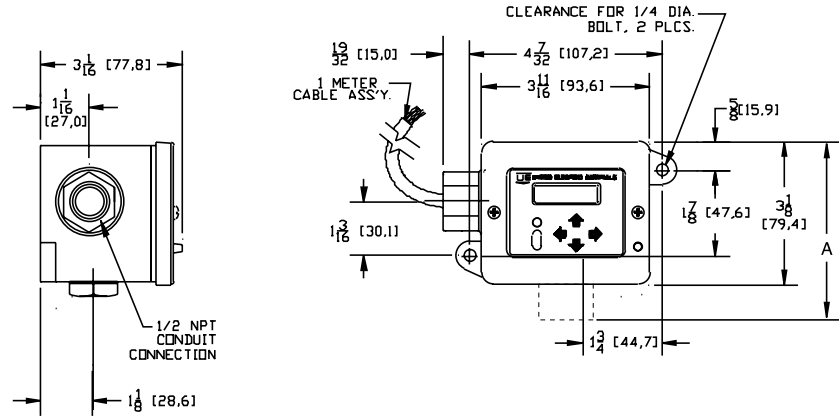

D2B CONFIGURATION

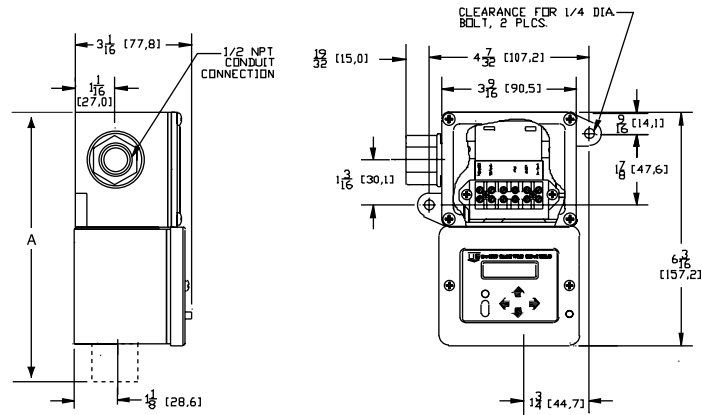

D2D & D2E CONFIGURATIONS

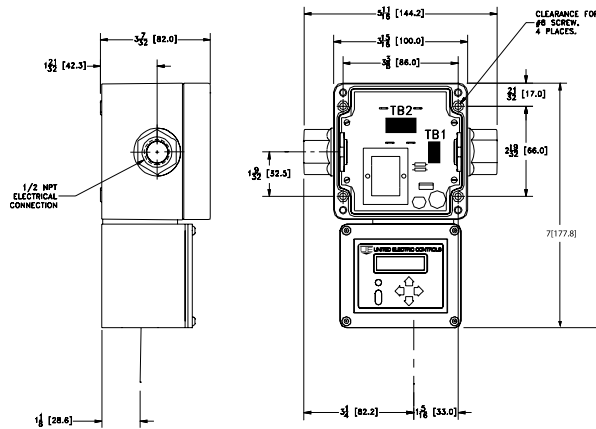

SEE SENSOR
DETAILS

DIMENSIONAL DRAWINGS

SENSOR DETAILS

Gauge Pressure Sensor

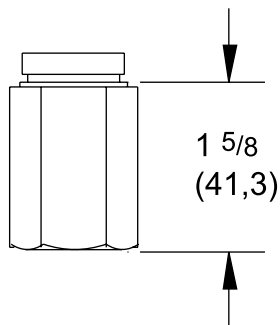

1/2" NPT Process Connection

Local Temperature Sensor

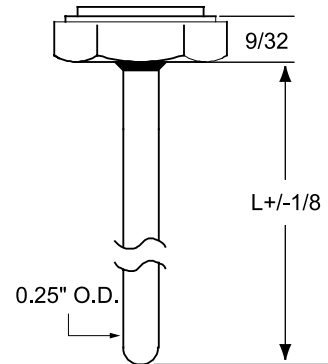

Model	DIM "L" (IN.)
L1	4
L2	6
L3	10

High Temperature Remote Sensor

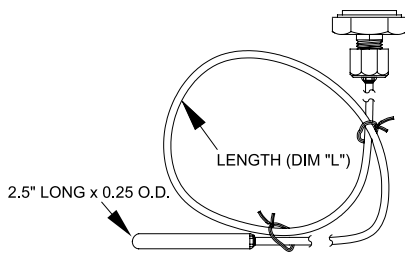

Model	DIM "L" (FT.)
H1, H4	6
H2, H5	10
H3, H6	20

Low Temperature Remote Sensor

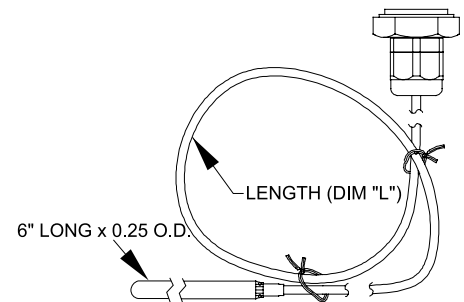

Model	DIM "L" (FT.)
R1	6
R2	10
R3	20



One Series Dual Output

One Series
Dual Output

DIMENSIONAL DRAWINGS

SENSOR DETAILS

Differential Pressure Sensor Dry Media

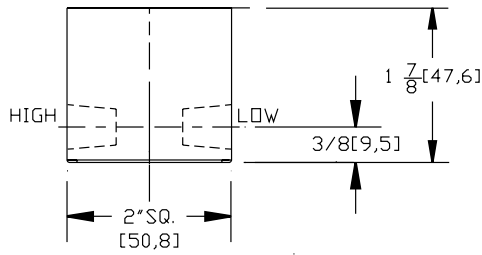

1/4" NPT Process Connections

Sanitary Sensor

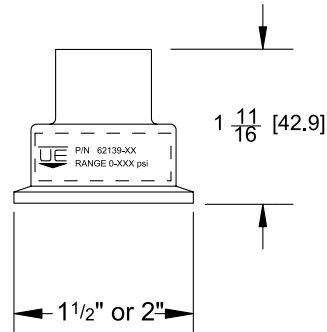

Stainless Steel Differential Pressure Sensor

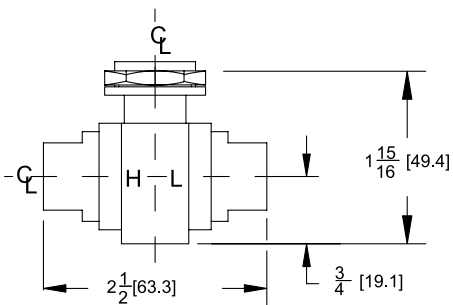

1/4" NPT Process Connections

M041 Secondary Seal

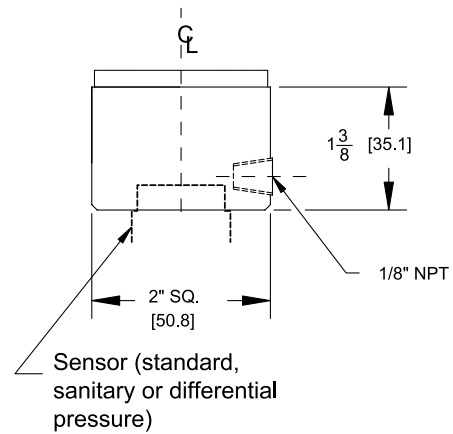

CONFIGURATION SELECTION GUIDE

POWER AND SWITCH

If you plan on powering the One Series with 18-30 VDC.				
Your Switch Output Voltage Requirements	Your Field Wiring Interface	One Series Switch Outputs (2) Circuit Type	IAW® Switch Output Type	Your One Series Configuration #
Up to 50 VDC or 50 VAC	Leadwires	Open Drain current sinking (outputs 100 mA, to 50VDC)	Not Available	D2A -
		100 mA, 18-30 VDC current sourcing outputs. One leg of each switch is tied to the power supply.	Not Available	D2A - - M031
		One free contact output 100 mA, 50 VDC/VAC, one sourcing 100 mA, 18-30 VDC output tied to the power supply. 4-20 mA output is not available.	Not Available	D2A - - M032
	Terminal Block	Open Drain current sinking outputs (100 mA, to 50VDC)	Not Available	D2B - -
		100 mA, 18-30 VDC current sourcing outputs. One leg of each switch is tied to the power supply.	Not Available	D2B - - M031
		One free contact output 100 mA, 50 VDC/VAC, one sourcing 100 mA, 18-30 VDC output tied to the power supply. 4-20 mA output is not available.	Not Available	D2B - - M032

One Series Dual Output

One Series Dual Output

POWER AND SWITCH

If you plan on powering the One Series with 115 VAC:				
Your Switch Output Voltage Requirements	Your Field Wiring Interface	One Series Switches (2) Output Circuit Type	IAW® Switch Output Type	Your One Series Configuration #
Up to 50 VDC/VAC	Terminal Block	50 VDC/VAC @100 mA PhotoMOS relay with free contacts	Not Available	D2D - - - M034
12 to 280 VAC		1 Amp SSR @ 12 to 280 VAC, 10 mA minimum load	Not Available	D2D - - - M035
If you plan on powering the One Series with 230 VAC:				
Up to 50 VDC/VAC	Terminal Block	50 VDC/VAC @100 mA PhotoMOS with free contacts	Not Available	D2E - - - M034
12 to 280 VAC		1 Amp SSR @ 12 to 280 VAC, 10 mA minimum load	Not Available	D2E - - - M035

ALTERNATIVE PRODUCTS FROM UE

One Series Single Switch and 2-Wire Electronic Pressure and Temperature switches, with remote I Am Working diagnostics signal

- Solid-state reliability with health-checking diagnostics
- Available with innovative low power "2-Wire" model for discrete input to PLC's or DCS; or models to switch 115/230 VAC loads
- Enclosure type 4X design, approved for Class I, Division 2 hazardous or Div. 1/Zone 0 intrinsically safe locations
- Digital display and tamper-proof keypad adjustment of set point and deadband
- Optional 4-20 mA analog output



120 Series Electromechanical Switches

- Wide selection of explosion-proof line of pressure, differential, pressure and temperature models
- UL, cUL, Cenelec EE xd certified for hazardous locations
- Single or dual switch outputs
- Internal or external set point adjustment



460 Series Pressure Transmitters

- Welded, #316 Stainless steel construction
- CSA, NRTL/C, Cenelec EE xd certified for hazardous locations
- Ranges 0 to 15,000 psi
- Choice of field or factory-sealed zero and span calibration
- 4-20 mA or 0-4 VDC



117 SERIES Compact Electromechanical Switches

- Single Switch for Corrosive and Hazardous Division 2 Locations
- Compact pressure, differential pressure and temperature models
- Hermetically-sealed SPDT and DPDT output
- Approved for Class I, Division 2 hazardous locations
- Epoxy-coated weather-tight design houses stainless steel internal construction
- Convenient terminal block wiring



RECOMMENDED PRACTICES AND WARNINGS

United Electric Controls Company recommends careful consideration of the following factors when specifying and installing UE pressure and temperature units. Before installing a unit, the Installation and Maintenance instructions provided with unit must be read and understood.

- To avoid damaging unit, proof pressure and maximum temperature limits stated in literature and on nameplates must never be exceeded, even by surges in the system. Operation of the unit up to maximum pressure or temperature is acceptable on a limited basis (e.g., start-up, testing) but continuous operation must be restricted to the designated adjustable range. Excessive cycling at maximum pressure or temperature limits could reduce sensor life.
- A back-up unit is necessary for applications where damage to a primary unit could endanger life, limb or property. A high or low limit switch is necessary for applications where a dangerous runaway condition could result.
- The adjustable range must be selected so that incorrect, inadvertent or malicious setting at any range point cannot result in an unsafe system condition.
- Install unit where shock, vibration and ambient temperature fluctuations will not damage unit or affect operation. Orient unit so that moisture does not enter the enclosure via the electrical connection. When appropriate, this entry point should be sealed to prevent moisture entry.
- Unit must not be altered or modified after shipment. Consult UE if modification is necessary.
- Monitor operation to observe warning signs of possible damage to unit, such as drift in set point or faulty display. Check unit immediately.
- Preventative maintenance and periodic testing is necessary for critical applications where damage could endanger property or personnel.
- For all applications, a factory set unit should be tested before use.
- Electrical ratings stated in literature and on nameplate must not be exceeded. Overload on a switch can cause damage, even on the first cycle. Wire unit according to local and national electrical codes, using wire size recommended in installation sheet.
- Do not mount unit in ambient temp. exceeding published limits.

LIMITED WARRANTY

Seller warrants that the product hereby purchased is, upon delivery, free from defects in material and workmanship and that any such product which is found to be defective in such workmanship or material will be repaired or replaced by Seller (Ex-works, Factory, Watertown, Massachusetts, INCOTERMS); provided, however, that this warranty applies only to equipment found to be so defective within a period of 36 months from the date of manufacture by the Seller. Seller shall not be obligated under this warranty for alleged defects which examination discloses are due to tampering, misuse, neglect, improper storage, and in any case where products are disassembled by anyone other than authorized Seller's representatives. EXCEPT FOR THE LIMITED WARRANTY OF REPAIR AND REPLACEMENT STATED ABOVE, SELLER DISCLAIMS ALL WARRANTIES WHATSOEVER WITH RESPECT TO THE PRODUCT, INCLUDING ALL IMPLIED WARRANTIES OF MERCHANTABILITY OR FITNESS FOR ANY PARTICULAR PURPOSE.

LIMITATION OF SELLER'S LIABILITY

Seller's liability to Buyer for any loss or claim, including liability incurred in connection with (i) breach of any warranty whatsoever, expressed or implied, (ii) a breach of contract, (iii) a negligent act or acts (or negligent failure to act) committed by Seller, or (iv) an act for which strict liability will be inputted to seller, is limited to the "limited warranty" of repair and/or replacement as so stated in our warranty of product. In no event shall the Seller be liable for any special, indirect, consequential or other damages of a like general nature, including, without limitation, loss of profits or production, or loss or expenses of any nature incurred by the buyer or any third party.

UE specifications subject to change without notice.

U.S. SALES OFFICES

United Electric Controls
32 Highland Rd.
South Hampton, NH 03827
Phone: 603-394-0078
FAX: 603-394-0175

United Electric Controls
28 N. Wise Ave.
Freeport, IL 61032
Phone: 815-235-3501
FAX: 815-235-3847

United Electric Controls
1022 Vineyard Drive
Conyers, GA 30013
Phone: 770-483-8400
FAX: 770-929-8716

United Electric Controls
5829 Grazing Court
Mason, OH 45040
Phone: 513-398-3175
FAX: 513-398-3076

United Electric Controls
102 Salazar Court
Clayton, CA 94517
Phone: 925-524-0210
FAX: 925-524-0210

United Electric Controls
27 Summit Terrace
Sparta, NJ 07871
Phone: 973-271-2550
FAX: 973-729-6099

United Electric Controls
4306 Lakeshore Forest Drive
Missouri City, TX 77459
Phone: 281-431-8134
FAX: 281-431-8158

INTERNATIONAL OFFICES

AUSTRALIA
United Electric Controls
(Australia) PTY Ltd
Unit 2, 615 Warrigal Road
Locked Bag 600
Ashburton, Victoria
3147, Australia
Phone: 613-9567-0750
FAX: 613-9567-0755

BELGIUM
United Electric Controls-Europe
G. Van Gervenstraat 19A
B-9120 Beveren-Waas, Belgium
Phone: 32-37554-383
FAX: 32-37552-747

CANADA
United Electric Controls
(Canada) Ltd
5320 Bradco Boulevard
Mississauga, Ontario
L4W 1G7 Canada
Phone: 905-625-5082
FAX: 905-625-5709

GERMANY
United Electric Controls
An Der Zentlinde 21
D-64711 Erbach, Germany
Phone: 496-062-7400
FAX: 496-062-7501

MALAYSIA
United Electric Controls, Far East
No. 1-2-2, 2nd Floor
Jalan 4/101C
Cheras Business Centre
Batu 5, Jalan Cheras
56100 Kuala Lumpur, Malaysia
Phone: 603-9133-4122
FAX: 603-9133-4155



UNITED ELECTRIC
CONTROLS

180 Dexter Avenue, P.O. Box 9143
Watertown, MA 02471-9143 USA
Telephone: 617 926-1000 Fax: 617 926-2568
<http://www.ueonline.com>

EMCO5000303